

Product Specification

	Model: XTPC14TN02-01	Rev. No.	Issued Date.	Page.
		A	2016,09,13	1 / 19

Thin-Film-Transistor LCD Module Model:XTPC14TN02-01

Acceptance

Approved and Checked by

Approved by	Checked by		Made by

Product Specification

	Model: XTPC14TN02-01	Rev. No.	Issued Date.	Page.
		A	2016,09,13	3 / 19

1. General Description and Features

XTPC14TN02-01 is a TM (Transmissive) type color active matrix TFT (Thin Film Transistor) liquid crystal display (LCD) that uses amorphous silicon TFT as a switching device. This model is composed of a TFT-LCD module, a driver circuit and a back-light unit. The resolution of a 1.44" contains 128RGBx128 dots and can display up to 262K/65K colors. The following table described the features of XTPC14TN02-01

LCD Module

Item	Specification	Unit
Screen Size	1.44inches	Diagona
Display Resolution	128RGB(H)x128(V)	Dot
Active Area	25.5 (H) x 26.5 (V)	mm
Outline Dimension	30.6(W) x 34.8(H) x 2.5 (D)	mm
Display Mode	Normally white/Transmissive	--
Pixel Arrangement	RGB-Vertical Stripe	--
Display Color	262K/65K	--
Gray scale inversion Direction	12 o'clock	
Viewing Direction	6 o'clock	--
Drive IC	ST7735S	--
Surface luminance	100 cd/m ²	

Product Specification				
	Model: XTPC14TN02-01	Rev. No.	Issued Date.	Page.
		A	2016,09,13	4 / 19

2.Mechanical Information

Item		Min.	Typ.	Max.	Unit	Note
Module Size	Horizontal (H)	--	30.6	--	mm	--
	Vertical (V)	--	34.8	--	mm	(1)
	Thickness (T)	--	2.5	--	mm	(2)
Weight		--	N/A	--	g	--

Note (1) Not include FPC.

Refer to the Outline Dimension for further information.

(2) Back-light unit are included.

3.Electrical Specifications

3.1 Absolute Max. Ratings

3.1.1 Absolute Ratings of Environment

If the operating condition exceeds the following absolute maximum ratings, the TFT LCD module may be damaged permanently.

(Ta=25±2°C, V_{SS}=GND=0)

Item	Symbol	Min.	Max.	Unit	Note
Operating temperature	T _{STG}	-20	70	°C	(1)
Storage temperature	T _{OPR}	-30	80	°C	(1,2,3)

Note (1) 95 % RH Max. (40 °C ≥ Ta). Maximum wet-bulb temperature at 39 °C or less. (Ta > 40 °C)
No condensation.

Note (2) In case of below 0°, the response time of liquid crystal (LC) becomes slower and the color of panel becomes darker than normal one. Level of retardation depends on temperature, because of LC's character

Note (3) Only operation is guaranteed at operating temperature. Contrast, response time, another display quality are evaluated at +25°C.

Product Specification

Model: XTPC14TN02-01	Rev. No.	Issued Date.	Page.
	A	2016,09,13	5 / 19

3.2 Electrical Absolute Rating

3.2.1 TFT-LCD Module

(Voltage Referenced to VSS)

Item	Symbol	Value		Unit	Condition
		Min.	Max.		
Digital Power Supply Voltage	VDD	VSS-0.3	5.0	V	--

3.2.2 Back-Light Unit

(Ta=25±2°C)

Item	Symbol	Min.	Max.	Unit	Note
current	I _f	--	30	mA	(1)
voltage	V _R	--	5	V	(1)

Note (1) Permanent damage to the device may occur if maximum values are exceeded or reverse voltage is loaded. Functional operation should be restricted to the conditions described under normal operating conditions.

Product Specification

	Model: XTPC14TN02-01	Rev. No.	Issued Date.	Page.
		A	2016,09,13	6 / 19

4 Electrical Characteristics

4.1 Backlight Unit

The back-light system is an edge-lighting type with six white LEDs (Light Emitting Diode).

(Ta=25±2°C)

Item	Symbol	Value			Unit	Condition
		Min.	Typ.	Max.		
LED Voltage	V _F	2.8	-	3.3	V	
LED Current	I _F	-	15	-	mA	
Power Consumption	P _{BL}	-	-	-	mW	

Note (1) Where $P_{BL} = V_F \times I_F$

Product Specification

	Model: XTPC14TN02-01	Rev. No.	Issued Date.	Page.
		A	2016,09,13	7 / 19

5 Input Terminal Pin Assignment

PIN.N O	SYMBOL	I/O/P	FUNCTI	MEMARK
1	LED A	P	POWER FOR BACKLIGHT(ANODE)	
2	LED K	P	POWER FOR BACKLIGHT(CATHODE)	
3	VGL	O	Power Output (Negative) Pin for Gate Driver	
4	VCL	O	A power output of VCOM voltage (Negative) generator	
5	AVDD	O	Power Pin for Analog Circuits	
6	VDD	P	POWER SUPPLY	
7	GND	P	POWER GROUND	
8-15	D0-D7	I/O	D[17:0] are used as MCU parallel interface data bus. -D0 is the serial input/output signal in serial interface mode. -In serial interface, D[17:1] are not used and should be fixed at VDDI or DGND level.	
16	WR	I	-Write Enable in MCU Parallel Interface. -In 4-line SPI, this pin is used as D/CX (data/ command selection). -If not used, please fix this pin at VDDI or DGND level.	
17	CS	I	Chip Selection Pin -Low Enable	
18	RES	I	This signal will reset the device and it must be applied to properly initialize the chip. -Signal is active low	
19	D/C	I	Display data/command Selection Pin in MCU Interface. -D/CX=' 1' : Display Data or Parameter. -D/CX=' 0' : Command Data. -In Serial Interface, this is used as SCL. -If not used, please fix this pin at VDDI or DGND level	
20	RD	I	Read Enable in 8080 MCU Parallel Interface. -If not used, please fix this pin at VDDI or DGND leve	

Product Specification

	Model: XTPC14TN02-01	Rev. No.	Issued Date.	Page.
		A	2016,09,13	8 / 19

6 Optical Characteristics

ITEM	SYMBOL	CONDITION	Min.	TYP.	Max.	
Color Filter Chromacicity (Note.1)	White	x	0.285	0.305	0.325	
		y	0.314	0.334	0.354	
		Y	29.9	32.9	35.9	
	Red	x	$\theta = \phi = 0^\circ$	0.588	0.608	0.628
		y		0.296	0.316	0.336
		Y		17.8	20.8	23.8
	Green	x	$\theta = \phi = 0^\circ$	0.285	0.305	0.325
		y		0.536	0.556	0.576
		Y		57.6	61.6	65.6
	Blue	x	$\theta = \phi = 0^\circ$	0.115	0.135	0.155
		y		0.117	0.137	0.157
		Y		13.2	16.2	19.2
Transmittance(%) (Note.3)	T	$\theta = \phi = 0^\circ$	--	6	--	
NTSC			--	53%	--	

Note.1 These items are measured by C light.

Note.2 Definition of Viewing Angle(θ, ϕ),refer to Fig.1 as below :

Product Specification

Model: XTPC14TN02-01	Rev. No.	Issued Date.	Page.
	A	2016,09,13	9 / 19

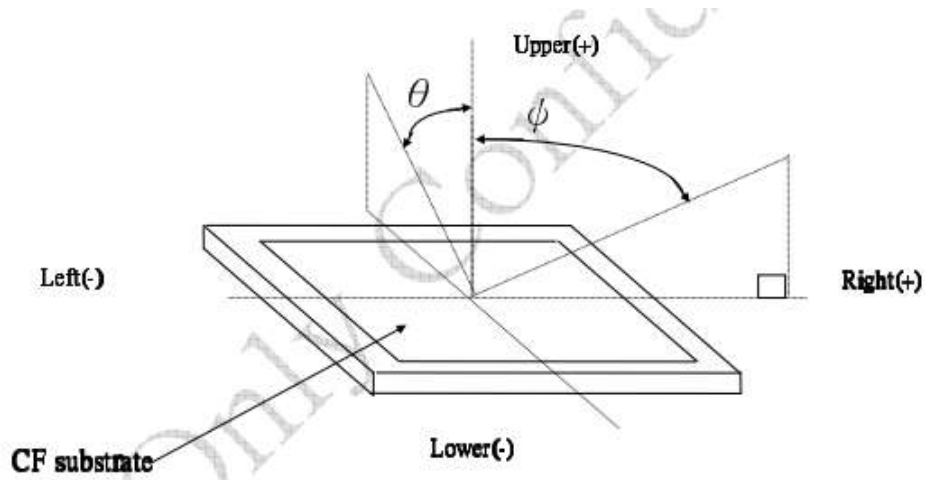
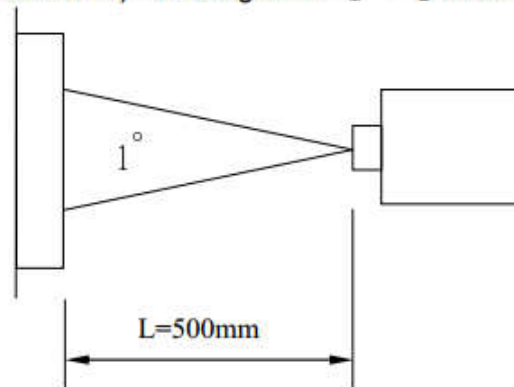

Fig.1 Definition of Viewing Angle

Note.3 Using CPT LC+ EWV Polarizer+Corresponding Backlight, reference only, Measure device : BM-5A (TOPCON) , viewing cone= 1° , $I_L=20\text{mA}$.



Product Specification

	Model: XTPC14TN02-01	Rev. No.	Issued Date.	Page.
		A	2016,09,13	10 / 19

7 Interface Timing

8.1 Parallel Interface Characteristics: 18, 16, 9 or 8-bit Bus (8080 Series MCU Interface)

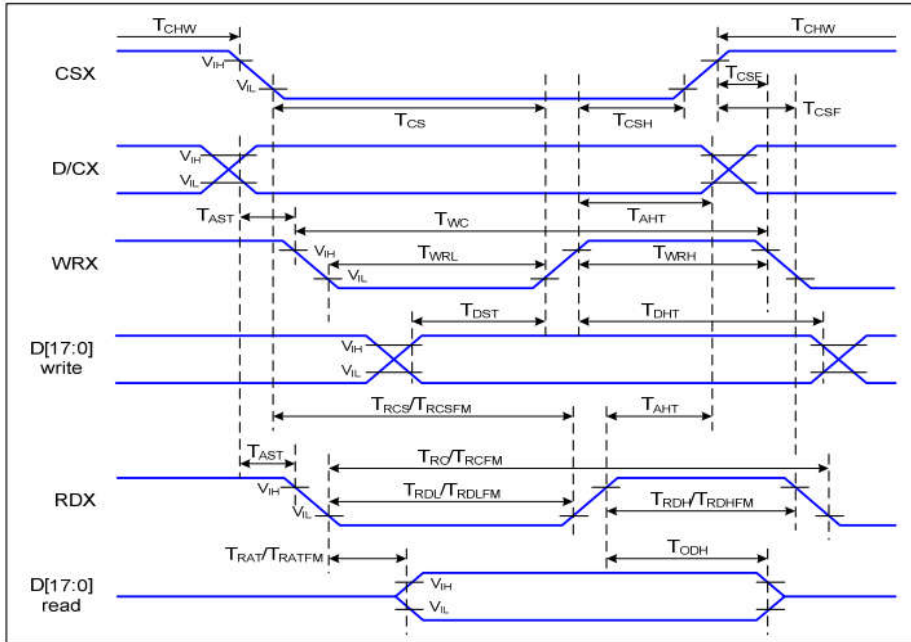

Figure 1 Parallel Interface Timing Characteristics (8080 Series MCU Interface)

Ta=25 °C, VDDI=1.65~3.7V, VDD=2.5~4.8V

Signal	Symbol	Parameter	Min	Max	Unit	Description
D/CX	TAST	Address Setup Time	0		ns	-
	TAHT	Address Hold Time (Write/Read)	10		ns	
CSX	TCHW	Chip Select "H" Pulse Width	0		ns	-
	TCS	Chip Select Setup Time (Write)	15		ns	
	TRCS	Chip Select Setup Time (Read ID)	45		ns	
	TRCSFM	Chip Select Setup time (Read FM)	355		ns	
	TCSF	Chip Select Wait Time (Write/Read)	10		ns	
	TCSH	Chip Select Hold Time	10		ns	
WRX	TWC	Write Cycle	66		ns	-
	TWRH	Control Pulse "H" Duration	15		ns	
	TWRL	Control Pulse "L" Duration	15		ns	
RDX (ID)	TRC	Read Cycle (ID)	160		ns	When Read ID Data
	TRDH	Control Pulse "H" Duration (ID)	90		ns	
	TRDL	Control Pulse "L" Duration (ID)	45		ns	

Product Specification

Model: XTPC14TN02-01

Rev. No.

Issued Date.

Page.

A

2016,09,13

11 / 19

RDX (FM)	TRCFM	Read Cycle (FM)	450		ns	When Read from Frame Memory
	TRDHF	Control Pulse "H" Duration (FM)	90		ns	
	TRDLF	Control Pulse "L" Duration (FM)	355		ns	
D[17:0]	TDST	Data Setup Time	10		ns	For CL=30pF
	TDHT	Data Hold Time	10		ns	
	TRAT	Read Access Time (ID)		40	ns	
	TRATFM	Read Access Time (FM)		340	ns	
	TODH	Output Disable Time	20	80	ns	

Table 4 8080 Parallel Interface Characteristics

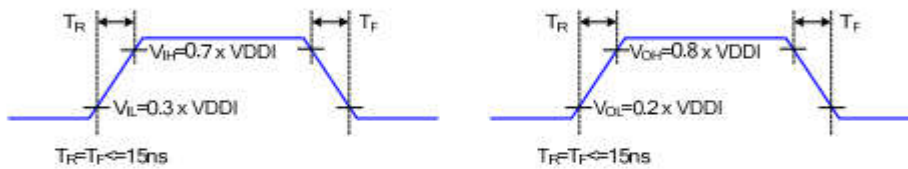

Figure 2 Rising And Falling Timing for Input And Output Signal

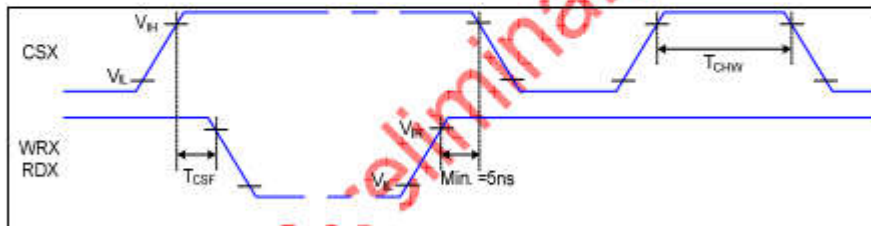

Figure 3 Chip Selection (CSX) Timing

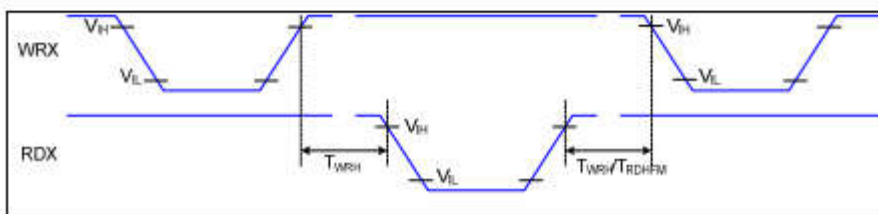
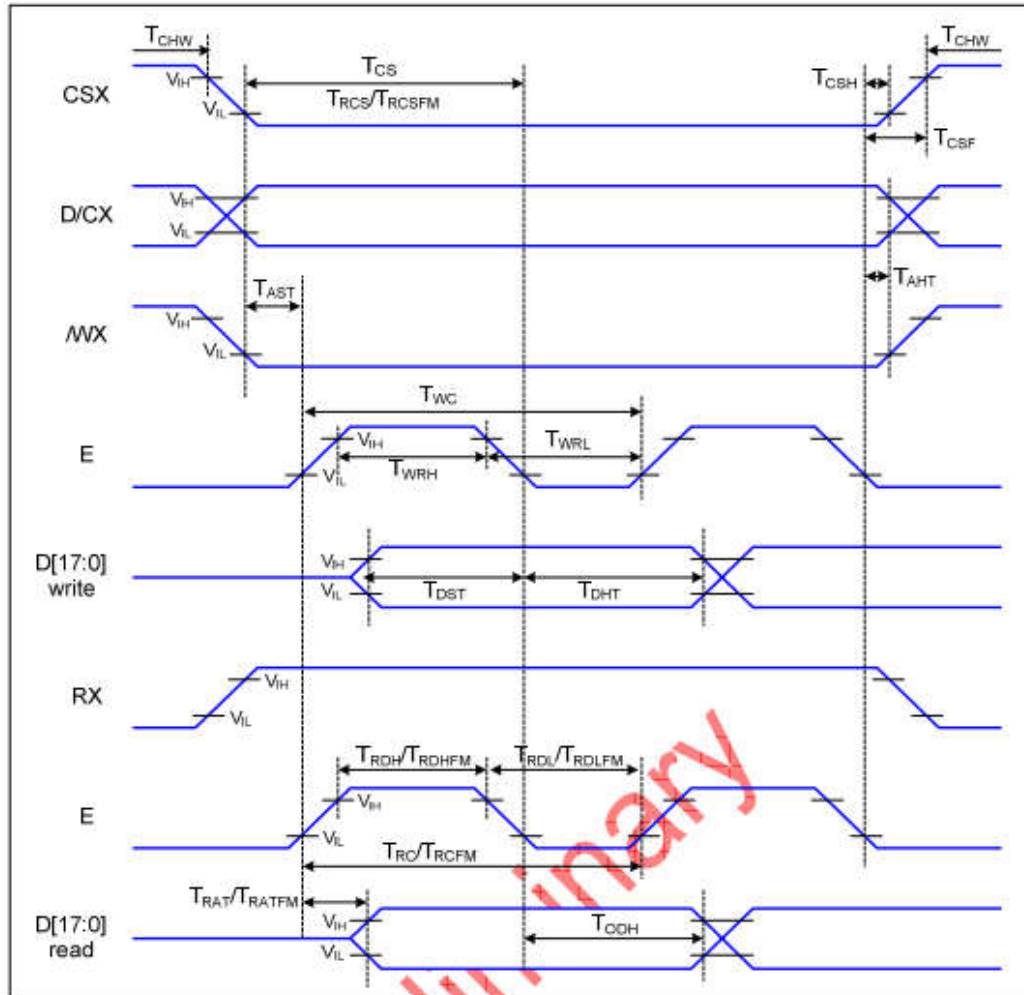

Figure 4 Write-to-Read And Read-to-Write Timing

Product Specification

	Model: XTPC14TN02-01	Rev. No.	Issued Date.	Page.
		A	2016,09,13	12 / 19

8.2 Parallel Interface Characteristics: 18, 16, 9 or 8-bit Bus (6800 Series MCU Interface)



Product Specification

	Model: XTPC14TN02-01	Rev. No.	Issued Date.	Page.
		A	2016,09,13	13 / 19

8 Reliability Condition for LCD

No change on display and in operation under the following test condition.

Condition: Unless otherwise specified, tests will be conducted under the following condition.

Temperature: 20±5°C Humidity: 65±5%RH

Tests will be not conducted under functioning state.

No.	Parameter	Condition	Notes
1	High Temperature Operating	70°C±2°C, 240hrs (Operation state)	--
2	Low Temperature Operating	-20°C±2°C, 240hrs (Operation state)	--
3	High Temperature Storage	80°C±2°C, 240hrs	--
4	Low Temperature Storage	-30°C±2°C, 240hrs	--
5	High Temperature and High Humidity Operation Test	60°C±2°C, 90%, 240hrs	--
6	Vibration Test	Total fixed amplitude: 1.5mm Vibration Frequency: 10±5Hz One cycle 60 seconds to 3 direction of X, Y, Z each 15 minutes.	--

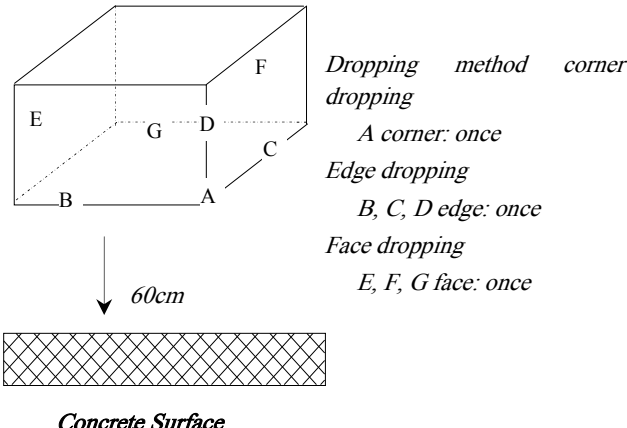
7.	Drop Test	<p>To be measured after dropping from 60cm high on the concrete surface in packing state.</p> <div style="text-align: center;">  </div>	--
----	-----------	---	----

- Notes:
1. No dew condensation to be observed.
 2. The function test shall be conducted after 4 hours storage at the normal temperature and humidity after removed from the test chamber.
 3. Vibration test will be conducted to the product itself without putting I in a container.

Product Specification

Model: XTPC14TN02-01

Rev. No.

Issued Date.

Page.

A

2016,09,13

14 / 19

9 Dimensional outlines

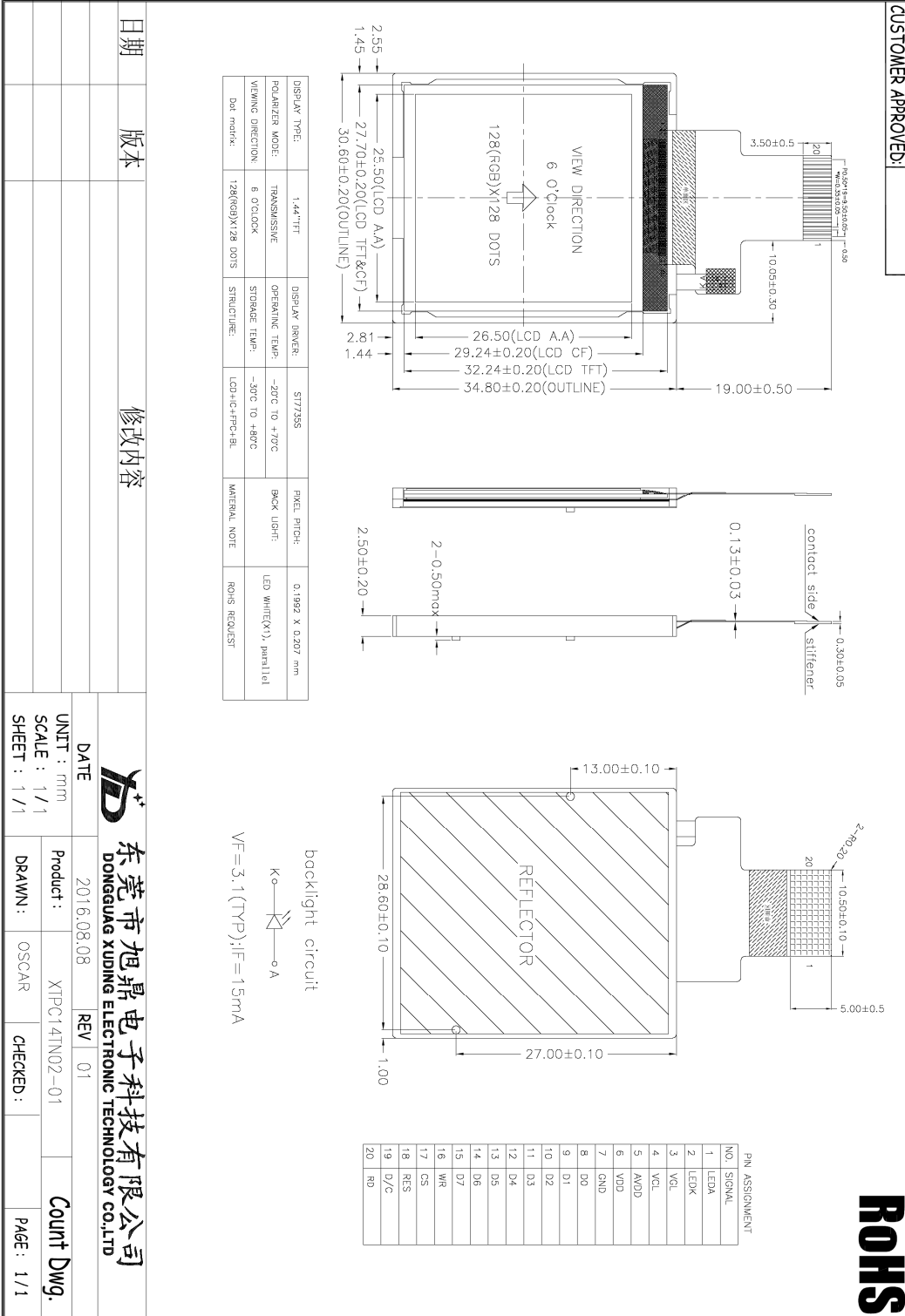

日期 版本

修改内容

DISPLAY TYPE:	1.44" TFT	DISPLAY ORDER:	ST7255S	PIXEL PITCH:	0.1992 X 0.2027 mm
POLARIZER MODE:	TRANSMISSIVE	OPERATING TEMP:	-20°C TO +70°C	BACK LIGHT:	LED WHITE(X), parallel
VIEWING DIRECTION:	6 O'CLOCK	STORAGE TEMP:	-30°C TO +80°C	MATERIAL NOTE:	MOIS-RESIST
Dot matrix:	128(RGB)X128 DOTS	STRUCTURE:	LCD+HC+FFC+ABL		

Product Specification				
	Model: XTPC14TN02-01	Rev. No.	Issued Date.	Page.
		A	2016,09,13	15 / 19

10 Incoming Inspection Standards

11.1 VISUAL & FUNCTION INSPECTION STANDARD

11.1.1 Inspection conditions

Inspection performed under the following conditions is recommended.

Temperature : $25\pm 5^{\circ}\text{C}$

Humidity : $65\%\pm 10\%\text{RH}$

Viewing Angle : Normal viewing Angle.

Illumination: Single fluorescent lamp (300 to 700Lux)

Viewing distance:30-50cm

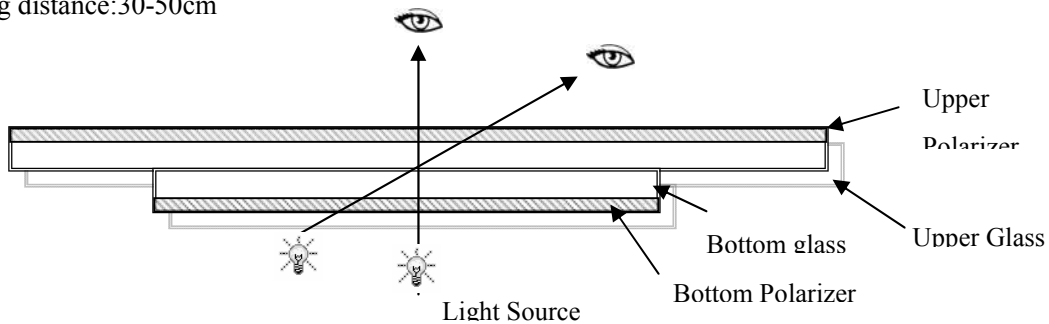

11.1.2 Definition

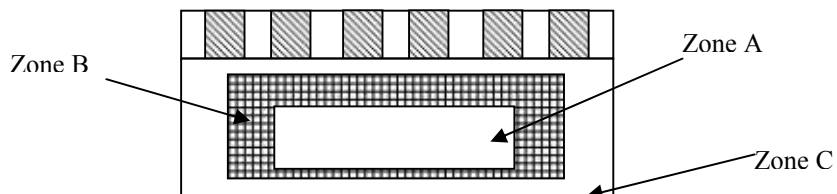

Zone A : Effective Viewing Area(Character or Digit can be seen)

Zone B : Viewing Area except Zone A

Zone C : Outside (Zone A+Zone B) which can not be seen after assembly by customer .)

Note:

As a general rule ,visual defects in Zone C can be ignored when it doesn't effect product function or appearance after assembly by customer.

11.1.3 Sampling Plan

According to GB/T 2828-2003 ; , normal inspection, Class II

Product Specification				
	Model: XTPC14TN02-01	Rev. No.	Issued Date.	Page.
		A	2016,09,13	16 / 19

AQL:

Major defect	Minor defect
0.65	1.5

LCD: Liquid Crystal Display , TP: Touch Panel , LCM: Liquid Crystal Module

No	Items to be inspected	Criteria	Classification of defects
1	Functional defects	1) No display, Open or miss line 2) Display abnormally, Short 3) Backlight no lighting, abnormal lighting. 4) TP no function	Major
2	Missing	Missing component	
3	Outline dimension	Overall outline dimension beyond the drawing is not allowed	
4	Color tone	Color unevenness, refer to limited sample	Minor
5	Soldering appearance	Good soldering , Peeling off is not allowed.	
6	LCD/Polarizer/TP	Black/White spot/line, scratch, crack, etc.	

11.1.4 Criteria (Visual)

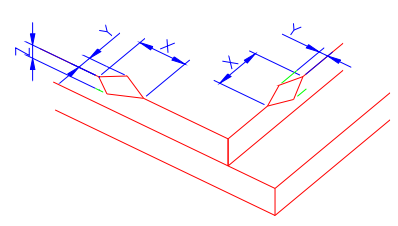
Number	Items	Criteria(mm)						
1.0 LCD Crack/Broken	(1) The edge of LCD broken	 <table border="1" data-bbox="845 1657 1388 1814"> <thead> <tr> <th>X</th> <th>Y</th> <th>Z</th> </tr> </thead> <tbody> <tr> <td>≤3.0mm</td> <td><Inner border line of the seal</td> <td>≤T</td> </tr> </tbody> </table>	X	Y	Z	≤3.0mm	<Inner border line of the seal	≤T
X	Y	Z						
≤3.0mm	<Inner border line of the seal	≤T						
NOTE: X: Length Y: Width								

Product Specification

	Model: XTPC14TN02-01	Rev. No.	Issued Date.	Page.
		A	2016,09,13	17 / 19

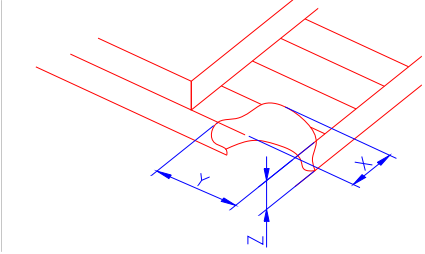
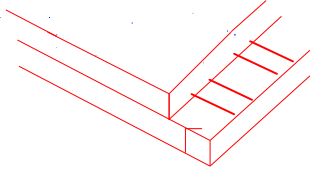
<p>Z: Height L: Length of ITO, T: Height of LCD</p>	<p>(2)LCD corner broken</p>	 <table border="1" style="margin: 10px auto; border-collapse: collapse;"> <thead> <tr> <th style="padding: 5px;">X</th> <th style="padding: 5px;">Y</th> <th style="padding: 5px;">Z</th> </tr> </thead> <tbody> <tr> <td style="padding: 5px;">$\leq 3.0\text{mm}$</td> <td style="padding: 5px;">$\leq L$</td> <td style="padding: 5px;">$\leq T$</td> </tr> </tbody> </table>	X	Y	Z	$\leq 3.0\text{mm}$	$\leq L$	$\leq T$
X	Y	Z						
$\leq 3.0\text{mm}$	$\leq L$	$\leq T$						
	<p>(3) LCD crack</p>	 <p style="text-align: center;">Crack Not allowed</p>						

Product Specification

Model: XTPC14TN02-01	Rev. No.	Issued Date.	Page.
	A	2016,09,13	18 / 19

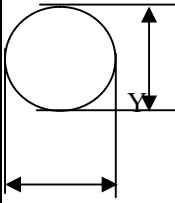
Number	Items	Criteria (mm)																																																																	
2.0	Spot defect  $\Phi = (X+Y)/2$	① light dot (LCD/TP/Polarizer black/white spot, light dot, pinhole, dent, stain) <table border="1" style="width: 100%; border-collapse: collapse;"> <thead> <tr> <th rowspan="2" style="text-align: center;">Zone Size (mm)</th> <th colspan="3" style="text-align: center;">Acceptable Qty</th> </tr> <tr> <th style="text-align: center;">A</th> <th style="text-align: center;">B</th> <th style="text-align: center;">C</th> </tr> </thead> <tbody> <tr> <td style="text-align: center;">$\Phi \leq 0.10$</td> <td colspan="3" style="text-align: center;">Ignore</td> </tr> <tr> <td style="text-align: center;">$0.10 < \Phi \leq 0.15$</td> <td colspan="3" style="text-align: center;">3(distance $\geq 10\text{mm}$)</td> </tr> <tr> <td style="text-align: center;">$0.15 < \Phi \leq 0.2$</td> <td colspan="3" style="text-align: center;">1</td> </tr> <tr> <td style="text-align: center;">$0.2 < \Phi$</td> <td colspan="3" style="text-align: center;">0</td> </tr> </tbody> </table> ② Dim spot (LCD/TP/Polarizer dim dot, light leakage, dark spot) <table border="1" style="width: 100%; border-collapse: collapse;"> <thead> <tr> <th rowspan="2" style="text-align: center;">Zone Size (mm)</th> <th colspan="3" style="text-align: center;">Acceptable Qty</th> </tr> <tr> <th style="text-align: center;">A</th> <th style="text-align: center;">B</th> <th style="text-align: center;">C</th> </tr> </thead> <tbody> <tr> <td style="text-align: center;">$\Phi \leq 0.1$</td> <td colspan="3" style="text-align: center;">Ignore</td> </tr> <tr> <td style="text-align: center;">$0.1 < \Phi \leq 0.2$</td> <td colspan="3" style="text-align: center;">2(distance $\geq 10\text{mm}$)</td> </tr> <tr> <td style="text-align: center;">$0.2 < \Phi \leq 0.3$</td> <td colspan="3" style="text-align: center;">1</td> </tr> <tr> <td style="text-align: center;">$\Phi > 0.3$</td> <td colspan="3" style="text-align: center;">0</td> </tr> </tbody> </table> ③ Polarizer accidented spot <table border="1" style="width: 100%; border-collapse: collapse;"> <thead> <tr> <th rowspan="2" style="text-align: center;">Zone Size (mm)</th> <th colspan="3" style="text-align: center;">Acceptable Qty</th> </tr> <tr> <th style="text-align: center;">A</th> <th style="text-align: center;">B</th> <th style="text-align: center;">C</th> </tr> </thead> <tbody> <tr> <td style="text-align: center;">$\Phi \leq 0.2$</td> <td colspan="3" style="text-align: center;">Ignore</td> </tr> <tr> <td style="text-align: center;">$0.2 < \Phi \leq 0.5$</td> <td colspan="3" style="text-align: center;">2(distance $\geq 10\text{mm}$)</td> </tr> <tr> <td style="text-align: center;">$\Phi > 0.5$</td> <td colspan="3" style="text-align: center;">0</td> </tr> </tbody> </table>	Zone Size (mm)	Acceptable Qty			A	B	C	$\Phi \leq 0.10$	Ignore			$0.10 < \Phi \leq 0.15$	3(distance $\geq 10\text{mm}$)			$0.15 < \Phi \leq 0.2$	1			$0.2 < \Phi$	0			Zone Size (mm)	Acceptable Qty			A	B	C	$\Phi \leq 0.1$	Ignore			$0.1 < \Phi \leq 0.2$	2(distance $\geq 10\text{mm}$)			$0.2 < \Phi \leq 0.3$	1			$\Phi > 0.3$	0			Zone Size (mm)	Acceptable Qty			A	B	C	$\Phi \leq 0.2$	Ignore			$0.2 < \Phi \leq 0.5$	2(distance $\geq 10\text{mm}$)			$\Phi > 0.5$	0		
Zone Size (mm)	Acceptable Qty																																																																		
	A	B	C																																																																
$\Phi \leq 0.10$	Ignore																																																																		
$0.10 < \Phi \leq 0.15$	3(distance $\geq 10\text{mm}$)																																																																		
$0.15 < \Phi \leq 0.2$	1																																																																		
$0.2 < \Phi$	0																																																																		
Zone Size (mm)	Acceptable Qty																																																																		
	A	B	C																																																																
$\Phi \leq 0.1$	Ignore																																																																		
$0.1 < \Phi \leq 0.2$	2(distance $\geq 10\text{mm}$)																																																																		
$0.2 < \Phi \leq 0.3$	1																																																																		
$\Phi > 0.3$	0																																																																		
Zone Size (mm)	Acceptable Qty																																																																		
	A	B	C																																																																
$\Phi \leq 0.2$	Ignore																																																																		
$0.2 < \Phi \leq 0.5$	2(distance $\geq 10\text{mm}$)																																																																		
$\Phi > 0.5$	0																																																																		

Product Specification

	Model: XTPC14TN02-01	Rev. No.	Issued Date.	Page.
		A	2016,09,13	19 / 19

	Line defect (LCD/TP /Polarizer black/white line, scratch, stain)	<table border="1" style="width: 100%; border-collapse: collapse; text-align: center;"> <thead> <tr> <th rowspan="2">Width(mm)</th> <th rowspan="2">Length(mm)</th> <th colspan="3">Acceptable Qty</th> </tr> <tr> <th>A</th> <th>B</th> <th>C</th> </tr> </thead> <tbody> <tr> <td>$\Phi \leq 0.03$</td> <td>Ignore</td> <td colspan="2">Ignore</td> <td rowspan="3">Ignore</td> </tr> <tr> <td>$0.03 < W \leq 0.05$</td> <td>$L \leq 3.0$</td> <td colspan="2">$N \leq 2$</td> </tr> <tr> <td>$0.05 < W \leq 0.08$</td> <td>$L \leq 2.0$</td> <td colspan="2">$N \leq 2$</td> </tr> <tr> <td>$0.08 < W$</td> <td colspan="4">Define as spot defect</td> </tr> </tbody> </table>	Width(mm)	Length(mm)	Acceptable Qty			A	B	C	$\Phi \leq 0.03$	Ignore	Ignore		Ignore	$0.03 < W \leq 0.05$	$L \leq 3.0$	$N \leq 2$		$0.05 < W \leq 0.08$	$L \leq 2.0$	$N \leq 2$		$0.08 < W$	Define as spot defect			
Width(mm)	Length(mm)	Acceptable Qty																										
		A	B	C																								
$\Phi \leq 0.03$	Ignore	Ignore		Ignore																								
$0.03 < W \leq 0.05$	$L \leq 3.0$	$N \leq 2$																										
$0.05 < W \leq 0.08$	$L \leq 2.0$	$N \leq 2$																										
$0.08 < W$	Define as spot defect																											
3.0	Polarizer Bubble	<table border="1" style="width: 100%; border-collapse: collapse; text-align: center;"> <thead> <tr> <th rowspan="2">Zone Size (mm)</th> <th colspan="3">Acceptable Qty</th> </tr> <tr> <th>A</th> <th>B</th> <th>C</th> </tr> </thead> <tbody> <tr> <td>$\Phi \leq 0.2$</td> <td colspan="2">Ignore</td> <td rowspan="4">Ignore</td> </tr> <tr> <td>$0.2 < \Phi < 0.4$</td> <td colspan="2">2(distance ≥ 10mm)</td> </tr> <tr> <td>$0.4 < \Phi \leq 0.6$</td> <td colspan="2">1</td> </tr> <tr> <td>$0.6 < \Phi$</td> <td colspan="2">0</td> </tr> </tbody> </table>	Zone Size (mm)	Acceptable Qty			A	B	C	$\Phi \leq 0.2$	Ignore		Ignore	$0.2 < \Phi < 0.4$	2(distance ≥ 10 mm)		$0.4 < \Phi \leq 0.6$	1		$0.6 < \Phi$	0							
Zone Size (mm)	Acceptable Qty																											
	A	B	C																									
$\Phi \leq 0.2$	Ignore		Ignore																									
$0.2 < \Phi < 0.4$	2(distance ≥ 10 mm)																											
$0.4 < \Phi \leq 0.6$	1																											
$0.6 < \Phi$	0																											
4.0	SMT	According to IPC-A-610C class II standard . Function defect and missing part are major defect ,the others are minor defect.																										