

Specification for Approval

Customer: _____

Model Name: _____

Supplier Approval			Customer approval
R&D Designed	R&D Approved	QC Approved	

Table of Contents

List	Description	Page No.
	Cover	1
	Revision Record	2
	Table of Contents	3
1	Scope	4
2	General Information	4
3	External Dimensions	5
4	Interface Description	6
5	Absolute Maximum Ratings	7
6	Electrical Characteristics	7
7	Timing Characteristics	8
8	Backlight Characteristics	10
9	Optical Characteristics	11
10	Reliability Test Conditions And Methods	13
11	Inspection Standard	14
12	Handling Precautions	18
13	Precaution for Use	19
14	Packing Method	19

1. Scope

This specification defines general provisions as well as inspection standards for TFT module supplied by AMSON electronics.

If the event of unforeseen problem or unspecified items may occur, naturally shall negotiate and agree to solution

2. General Information

ITEM	STANDARD VALUES	UNITS
LCD type	2.0" TFT	--
Dot arrangement	320(RGB) × 240	dots
Color filter array	RGB vertical stripe	--
Display mode	TN / Transmissive / Normally White	--
Viewing Direction	12 o'clock (Gray scale inversion)	--
Driver IC	ILI9342	--
Module size	46.10 (W) * 40.96 (H) * 2.55(T)	mm
Active area	40.80 (W) * 30.60 (H)	mm
Dot pitch	0.0425 (W) * 0.1275 (H)	mm
Interface	3-wire SPI / RGB	--
Operating temperature	-20 ~ +70	°C
Storage temperature	-30 ~ +80	°C
Back Light	2 White LED In Parallel	--
Weight	TBD	g

3. External Dimensions

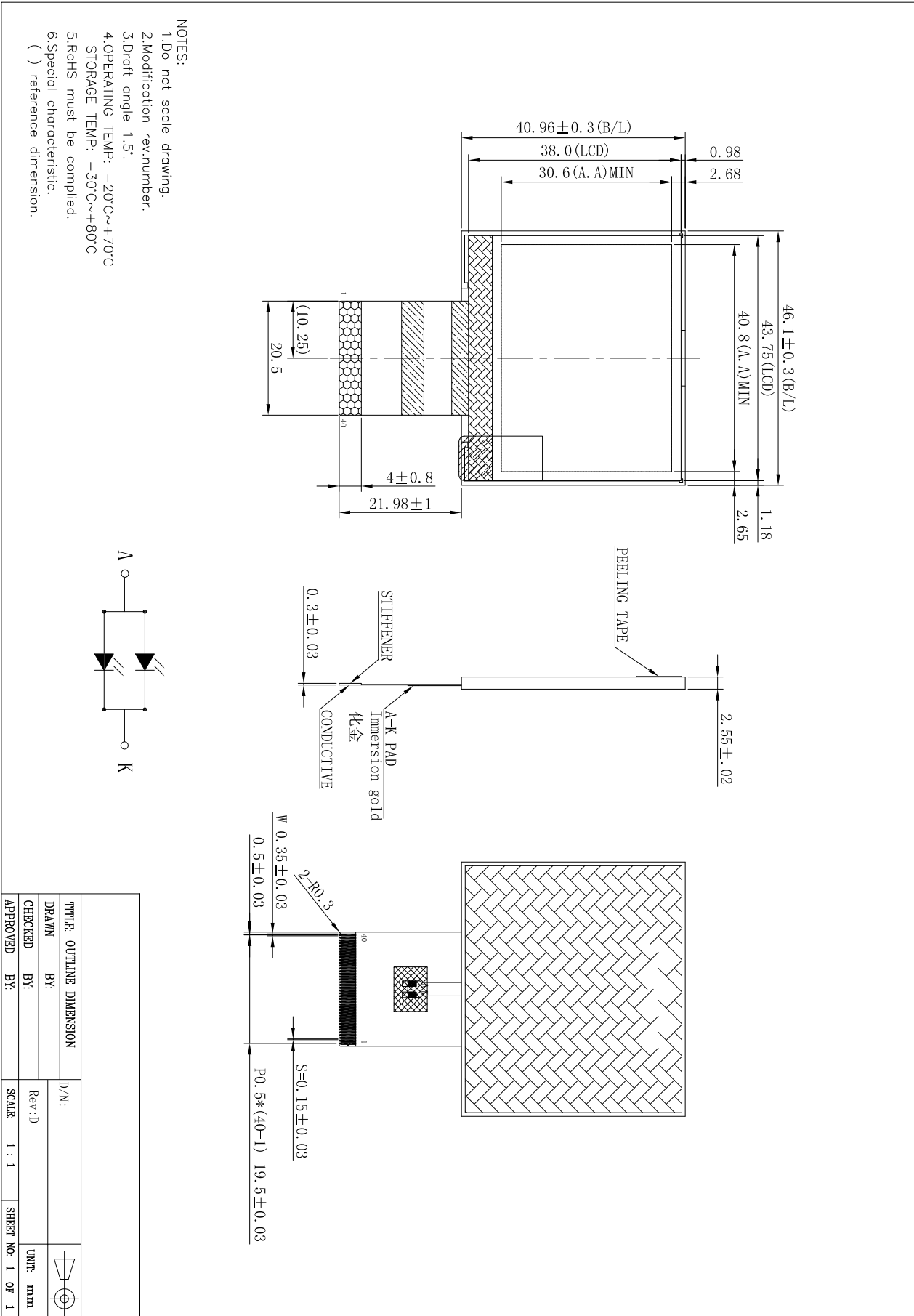

4. Interface Description

Pin	Symbol	I/O	Function
1	DUMMY	--	Dummy
2	DUMMY	--	Dummy
3	DUMMY	--	Dummy
4	DUMMY	--	Dummy
5	DUMMY	--	Dummy
6	DUMMY	--	Dummy
7	DUMMY	--	Dummy
8	DUMMY	--	Dummy
9	DUMMY	--	Dummy
10	VCOML	C	Capacitor for VCOM low
11	VCOMH	C	Capacitor for VCOM high
12	GND	--	Ground
13	DUMMY	--	Dummy
14	VCI	I	Power supply for analog circuit blocks
15	DUMMY	--	Dummy
16	DUMMY	--	Dummy
17	DUMMY	--	Dummy
18	DUMMY	--	Dummy
19	LEDK	G	LED Power: cathode
20	DUMMY	--	Dummy
21	DUMMY	--	Dummy
22	LEDA	P	LED Power: anode
23	GND	--	Ground
24	IOVCC	I	Power supply for interface logic circuit
25	VSYNC	I	Vertical sync input. Negative polarity
26	HSYNC	I	Horizontal sync input. Negative polarity
27	DCLK	I	Dot clock signal for RGB interface operation
28	GND	--	Ground
29	GND	--	Ground
30	DB0	I	Data Input :
31	DB1	I	Data Input :
32	DB2	I	Data Input :
33	DB3	I	Data Input :

34	DB4	I	Data Input :
35	DB5	I	Data Input :
36	SDA	I	Serial interface data line
37	SCL	C	Serial interface clock line
38	CS	C	Chip select input pin
39	NC	--	No connection
40	REST	I	System reset pin

5. Absolute Maximum Ratings

Item	Symbol	Min.	Max.	Unit
Logic Supply Voltage	IOVCC	-0.3	4.6	V
Analog Supply Voltage	VCI	-0.3	4.6	V
Input Voltage	Vin	-0.3	IOVCC+0.3	V
Operating Temperature	TOP	-20	70	°C
Storage Temperature	TST	-30	80	°C
Storage Humidity	HD	20	90	%RH

6. DC Characteristics

Item	Symbol	Min.	Typ.	Max.	Unit	Remark
Logic Supply Voltage	IOVCC	1.65	2.8	3.3	V	--
Analog Supply Voltage	VCI	2.5	2.8	3.3		
Input High Voltage	V _{IH}	0.7IOVCC	--	IOVCC	V	Digital input pins
Input Low Voltage	V _{IL}	GND	--	0.3IOVCC	V	Digital input pins
Output High Voltage	V _{OH}	0.8IOVCC	--	IOVCC	V	Digital output pins
Output Low Voltage	V _{OL}	GND	--	0.2IOVCC	V	Digital output pins
I/O Leak Current	I _{LI}	-0.1	--	0.1	uA	--

7. Timing Characteristics

7.1 Serial Interface Timing Characteristics (3-wire SPI)

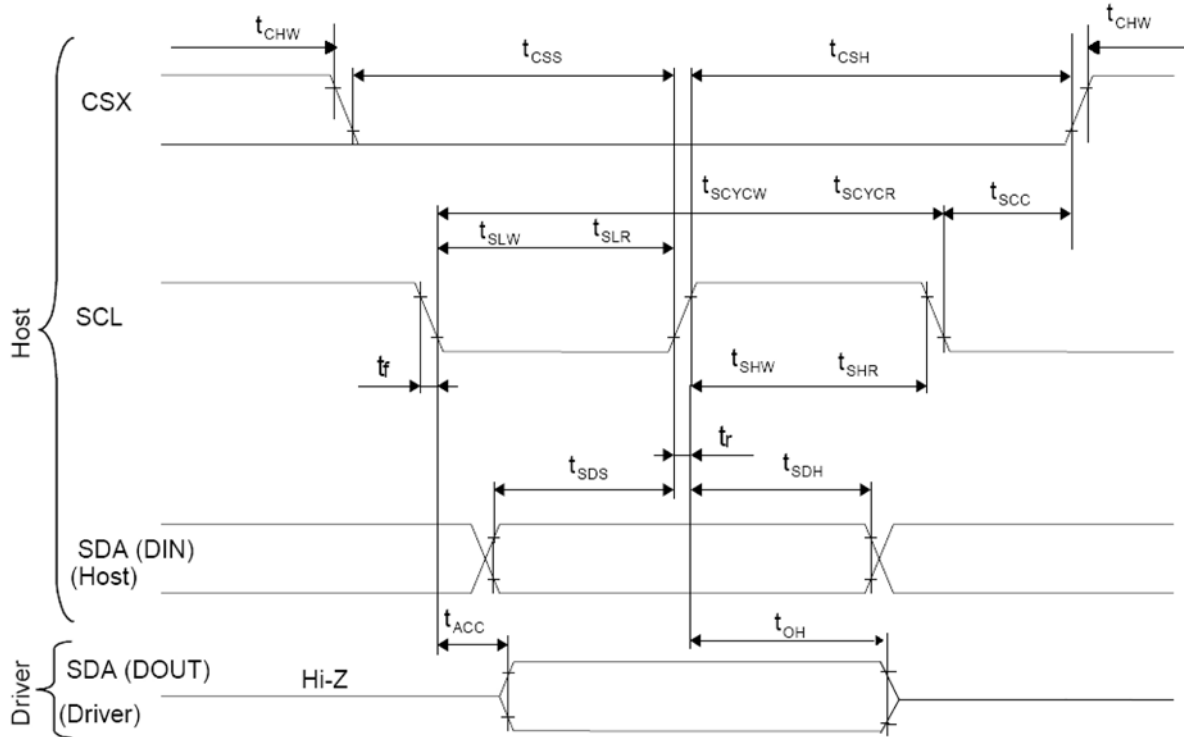

Signal	Symbol	Parameter	min	max	Unit	Description
SCL	tscycw	Serial Clock Cycle (Write)	100	-	ns	
	tshw	SCL "H" Pulse Width (Write)	35	-	ns	
	tslw	SCL "L" Pulse Width (Write)	35	-	ns	
	tscycr	Serial Clock Cycle (Read)	150	-	ns	
	tshr	SCL "H" Pulse Width (Read)	60	-	ns	
	tslr	SCL "L" Pulse Width (Read)	60	-	ns	
SDA (Input)	tsds	Data setup time (Write)	30	-	ns	
	tsdh	Data hold time (Write)	30	-	ns	
SDA (Output)	tacc	Access time (Read)	10	-	ns	
	toh	Output disable time (Read)	15	50	ns	
CSX	tsc	SCL-CSX	20	-	ns	
	tchw	CSX "H" Pulse Width	40	-	ns	
	tcss	CSX-SCL Time(write)	30	-	ns	
			30	-	ns	

Note: $T_a = 25\text{ }^\circ\text{C}$, $I_{OVCC}=1.65\text{V to }2.8\text{V}$, $V_{CI}=2.6\text{V to }3.3\text{V}$, $AGND=GND=0\text{V}$

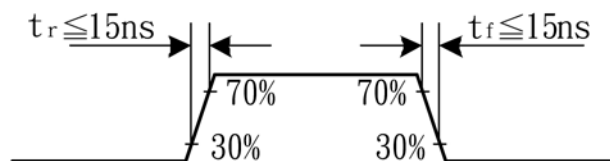

7.2 RGB Interface Timing Characteristics

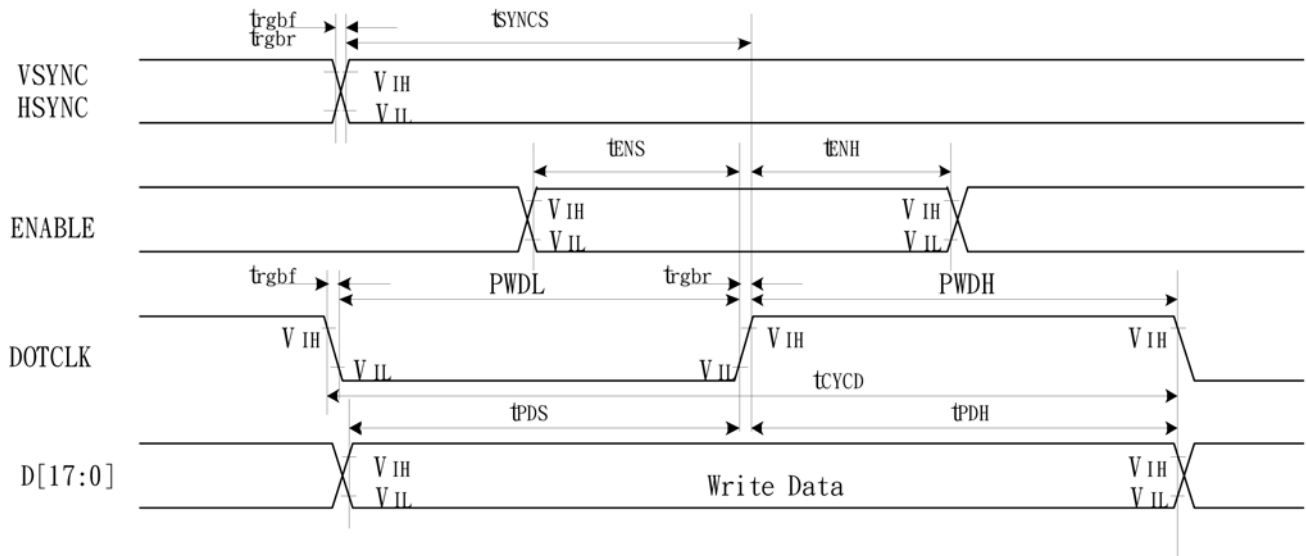

Signal	Symbol	Parameter	min	max	Unit	Description
VSYNC / HSYNC	t_{syncs}	VSYNC/HSYNC setup time	15	-	ns	18/16-bit bus RGB interface mode
	t_{synch}	VSYNC/HSYNC hold time	15	-	ns	
DE	t_{ens}	DE setup time	15	-	ns	
	t_{enh}	DE hold time	15	-	ns	
D[17:0]	t_{ps}	Data setup time	15	-	ns	
	t_{pdh}	Data hold time	15	-	ns	
DOTCLK	$PWDH$	DOTCLK high-level period	33	-	ns	
	$PWDL$	DOTCLK low-level period	33	-	ns	
	t_{cyd}	DOTCLK cycle time(18 bit)	100	-	ns	
	$t_{rgbr} \ t_{rgbl}$	DOTCLK, HSYNC, VSYNC rise/fall time	-	15	ns	
VSYNC / HSYNC	t_{syncs}	VSYNC/HSYNC setup time	15	-	ns	6-bit bus RGB interface mode
	t_{synch}	VSYNC/HSYNC hold time	15	-	ns	
DE	t_{ens}	DE setup time	15	-	ns	
	t_{enh}	DE hold time	15	-	ns	
D[17:0]	t_{ps}	Data setup time	15	-	ns	
	t_{pdh}	Data hold time	15	-	ns	
DOTCLK	$PWDH$	DOTCLK high-level pulse period	25	-	ns	
	$PWDL$	DOTCLK low-level pulse period	25	-	ns	
	t_{cyd}	DOTCLK cycle time	50	-	ns	
	$t_{rgbr} \ t_{rgbl}$	DOTCLK, HSYNC, VSYNC rise/fall time	-	15	ns	

Note: $T_a = -30$ to 70 °C, $IOVCC=1.65V$ to $2.8V$, $VCI=2.6V$ to $3.3V$, $AGND=GND=0V$

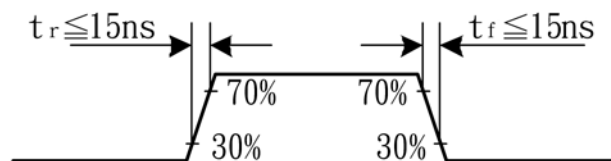

7.3 Reset Timing Characteristics

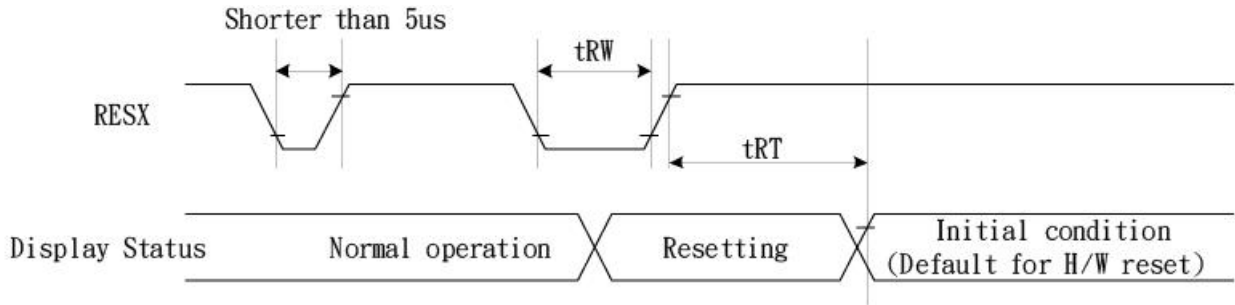

Signal	Symbol	Parameter	Min	Max	Unit
RESX	tRW	Reset pulse duration	10		uS
	tRT	Reset cancel		5 (note 1, 5)	mS
				120 (note 1, 6, 7)	mS

8. Backlight Characteristic

LED Circuit:

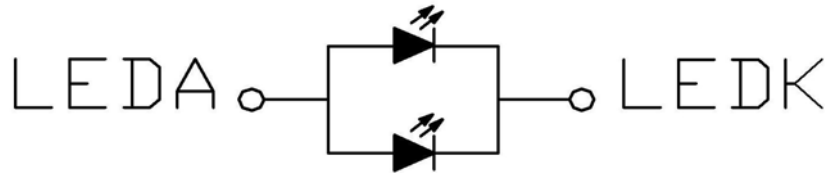

Item	Symbol	MIN	TYP	MAX	UNIT	Test Condition
Supply Voltage	Vf	3.0	3.3	3.5	V	If=40mA
Supply Current	If	-	40	50	mA	--
Luminous Intensity for LCM	--	180	230	--	cd/m ²	If=40mA
Uniformity for LCM	--	80	--	--	%	If=40mA
Backlight Color	White					

9. Optical Characteristics

ITEM	SYMBOL	CONDITION	MIN.	TYP.	MAX.	UNIT	REMARK
Brightness	BL	$\theta = \varphi = 0^\circ$	180	230	--	cd/m ²	Note2
Contrast Ratio	CR	$\theta = \varphi = 0^\circ$	--	600	--	--	Note3
Response Time	Tr	$\theta = \varphi = 0^\circ$	--	6	12	ms	Note4
	Tf		--	15	30		
Viewing Angle	Upper	θ	CR \geq 10	10	(45)	--	Note 5
	Down			30	(60)	--	
	Right	φ		45	(60)	--	
	Left			45	(60)	--	
Color Filter Chromaticity	White	X y	$\theta = \varphi = 0^\circ$	(0.26)	(0.31)	(0.36)	--
				(0.29)	(0.34)	(0.39)	--

Note1: Definition of Operation Voltage (Vop)

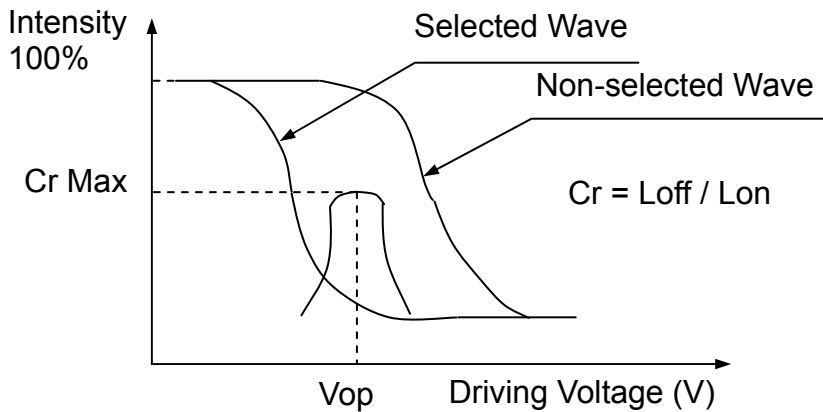

Note2: Definition of Luminance Uniformity : $L = L(\text{MIN}) / L(\text{MAX}) \times 100\%$

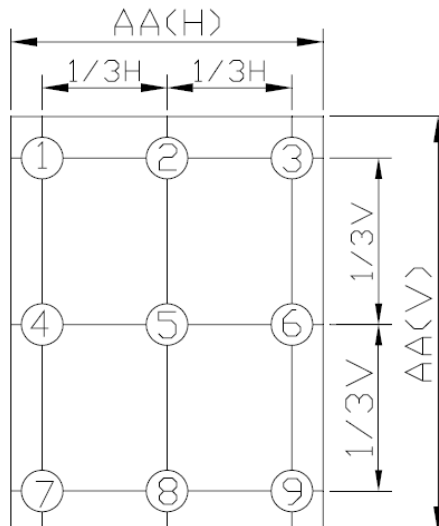

Note 3. Definition of Contrast Ratio:

$$CR = \text{White Luminance (ON)} / \text{Black Luminance (OFF)}$$

Note 4. Definition of response time : The response time is defined as the time interval between the 10% and 90% amplitudes.

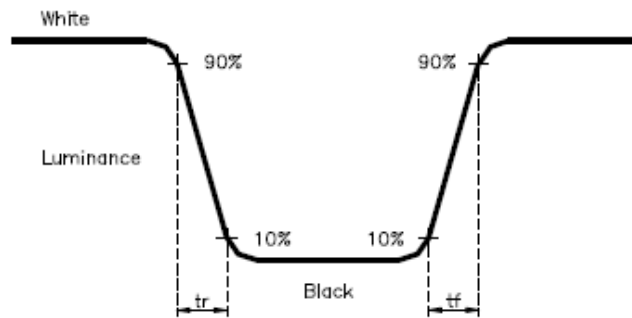

Note 5. Definition of view angle(θ , ψ) :

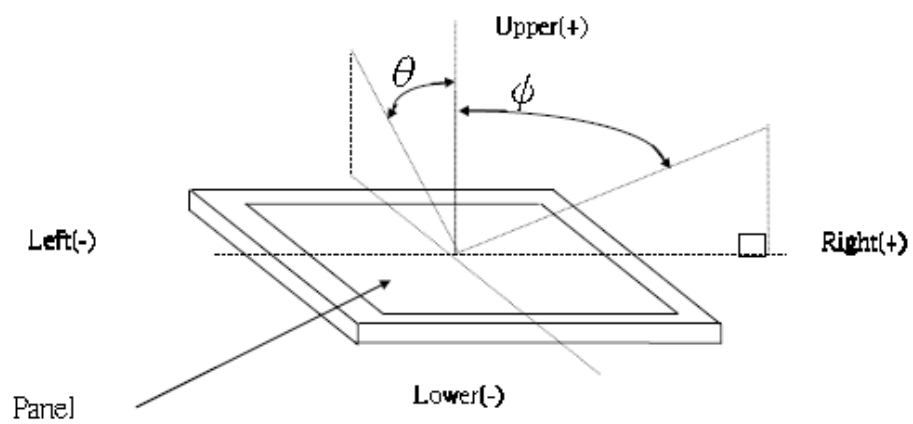

Note 6. Light source: C light.

10. Reliability Test Conditions and Methods

NO.	ITEM	CONDITION	CRITERION
1	High Temperature Operating	60°C 240 hrs	<ul style="list-style-type: none"> ◦ No Defect Of Operational Function In Room Temperature Are Allowable. ◦ Leakage current should be below double of initial value.
2	Low Temperature Operating	0°C 240 hrs	
3	High Temperature Non-Operating	70°C 240 hrs	
4	Low Temperature Non-Operating	-20°C 240 hrs	
5	High Temperature/ Humidity Non-Operating	60°C ,90%RH 240 hrs	
6	Temperature Shock Non-Operating	-20°C (30min) \longleftrightarrow 70°C (30min) (5min) 100 CYCLES	
7	Electrostatic Discharge Test Non-Operating	HBM:±2kV	

Note 1: Test after 24 hours in room temperature.

Note 2: The sampling above is individually for each reliability testing condition.

Note 3: The color fading of polarizing filter should not care.

Note 4: All of the reliability testing chamber above, is using D.I. water. (Min value: 1.0 MΩ-cm)

Note 5: In case of malfunction defect caused by ESD damage, if it would be recovered to normal state after resetting, it would be judged as a good part.

11. Inspection Standard

11.1 Definition Of Inspection Area

V.A: Viewing Area

A.A: Active Area

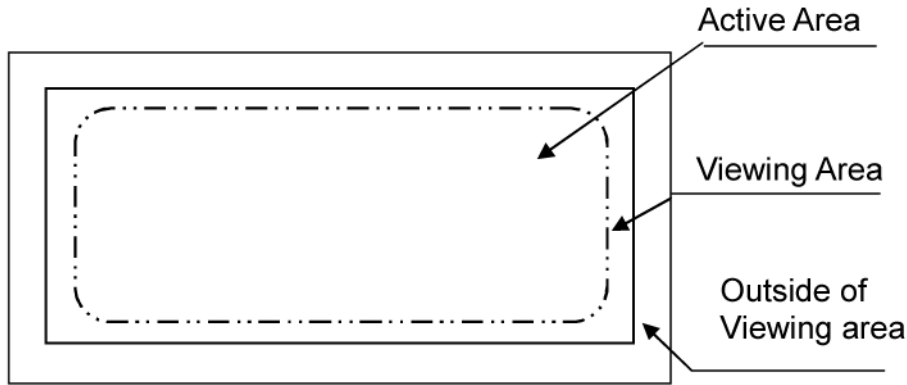

11.2 Items And Criteria

11.2.1 Visual inspection criterion in cosmetic

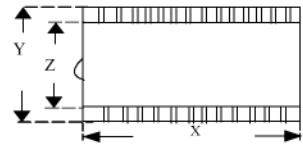
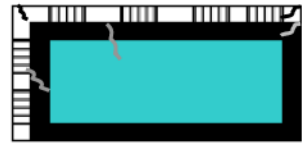
Glass defect			
No	Item	Criteria	Remark
1	Dimension (Minor)	By engineering diagram	
2	Crack (Major)	Extensive crack G RejectH	

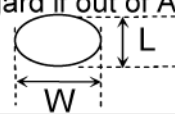
LCD appearance defect				
No	Item	Criteria	Remark	
1	Round type (Minor)	Defect Spec.	Permissible Q'ty	1: $I = (L+W)/2$, L: Length, W: Width 2: Disregard if out of A.A. 
		I * 0.2mm	Disregard	
		0.2mm < I < 0.3mm	2	
		I > 0.3mm	0	

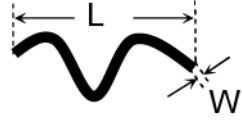
LCD appearance defect			
2	Line type (Minor)	Defect Spec.	Permissible Q'ty
		W* 0.5mm, L* 2.0mm	2
		W* 0.5mm, L>2.0mm	0
		1: L: Length, W: Width 2: Disregard if out of A.A 	
3	Polarizer bubble (Minor)	Defect Spec.	Permissible Q'ty
		Out of A.A	Disregard
		Within A.A	0
		1: $I = (L+W)/2$, L: Length, W: Width.	

FPC			
No	Item	Criteria	Remark
1	Copper peeling (Minor)	Copper peeling G RejectH	
2	No release film or Peeling (Minor)	No release film or peeling G RejectH	
3	Finger Spots, Impurities defect (Minor)	Defect Spec.	Permissible Q'ty
		IJ 0.35mm	2
		I >0.35mm	0
		1.No bridge 2. Disregard if the dirty removed	

Silicon			
No	Item	Criteria	Remark
1	Amount of silicon (Minor)	ITO exposed G RejectH	

Bezel			
No	Defect	Criteria	Remark
1	Oxidized spot (Minor)	Oxidized spot, rust G RejectH	
2	Outline deformation (Minor)	By engineering diagram	
3	Greasiness (Minor)	Greasiness G RejectH	
4	Spots, round Type (Minor)	HJ By engineering diagram G DisregardH	H=Total height (thickness)

Bezel			
5	Plating (Minor)	Bubble, peeling	G RejectH

11.2.2 Visual inspection criterion in electrical display

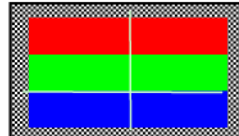
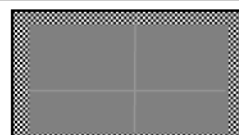
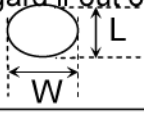
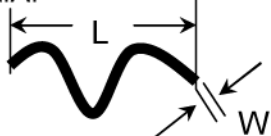
No	Defect	Criteria				Remark
1	No display (Major)	Not allowed				
2	Missing line (Major)	Not allowed				
3	Darker or lighter line (Major)	Not allowed				
No	Defect	Criteria				Remark
4	Weak line (Minor)	By limit sample				
5	Bright / Dark point (Minor)		A Area	B Area	Total	1:1sub-pixel: 1R or 1G or 1B 2:Point defect areaK 1/2 sub pixel. 2.Point distanceK 5mm 3.Refer to Note 1
		Bright point	0	1	1	
		Dark dot point	1	1	2	
		Bright +Dark point	1	2	3	
6	Round type (Minor)	Spec.		Permissible Qty		1.I $= (L+W)/2$, L: Length, W: Width 2. Disregard if out of A.A. 
		IJ	0.2mm	Disregard		
		0.2mm<IJ	0.3mm	2		
		I >0.3mm		0		
7	Line type (Minor)	Spec.		Permissible Qty		1. L: Length, W: Width 2. Disregard if out of A.A. 
		WJ	0.5mm, LJ	2.0mm	2	

		WJ 0.5mm, L>2.0mm	0	
8	Mura (Minor)	By 5% ND filter invisible		

Note 1

	1/4	1/2	1/4	
	B	B	B	1/4
	B	A	B	1/2
	B	B	B	1/4

Please Follow the section separate to judgment the Bright or Dark Dots

11.2.3 Others

1. Issues that are not defined in this document shall be discussed and agreed with both parties. (Customer and supplier)
2. Unless otherwise agreed upon in writing, the criteria shall be applied to both parties. (Customer and supplier)

12. Handling Precautions

12.1 Mounting method

The LCD panel of AMSON TFT module consists of two thin glass plates with polarizers which easily be damaged. And since the module is so constructed as to be fixed by utilizing fitting holes in the printed circuit board.

Extreme care should be needed when handling the LCD modules.

12.2 Caution of LCD handling and cleaning

When cleaning the display surface, Use soft cloth with solvent

[Recommended below] and wipe lightly

- Isopropyl alcohol
- Ethyl alcohol

Do not wipe the display surface with dry or hard materials that will damage the polarizer surface.

Do not use the following solvent:

- Water
- Aromatics

Do not wipe ITO pad area with the dry or hard materials that will damage the ITO patterns

Do not use the following solvent on the pad or prevent it from being contaminated:

- Soldering flux
- Chlorine (Cl) , Sulfur (S)

If goods were sent without being silicon coated on the pad, ITO patterns could be damaged due to the corrosion as time goes on.

If ITO corrosion happens by miss-handling or using some materials such as Chlorine (Cl), Sulfur (S) from customer, Responsibility is on customer.

12.3 Caution against static charge

The LCD module uses C-MOS LSI drivers, so we recommend that you:

Connect any unused input terminal to IOVCC or GND, do not input any signals before power is turned on, and ground your body, work/assembly areas, and assembly equipment to protect against static electricity.

12.4 packing

- Module employs LCD elements and must be treated as such.
- Avoid intense shock and falls from a height.
- To prevent modules from degradation, do not operate or store them exposed direct to sunshine or high temperature/humidity

12.5 Caution for operation

- It is an indispensable condition to drive LCD's within the specified voltage limit since the higher voltage than the limit causes the shorter LCD life.
- An electrochemical reaction due to direct current causes LCD's undesirable deterioration, so that the use of direct current drive should be avoided.
- Response time will be extremely delayed at lower temperature than the operating temperature range and on the other hand at higher temperature LCD's show dark color in them. However those phenomena do not mean malfunction or out of order with LCD's, which will come back in the specified operation temperature.
- If the display area is pushed hard during operation, some font will be abnormally displayed but it resumes normal condition after turning off once.
- Slight dew depositing on terminals is a cause for electro-chemical reaction resulting in terminal open circuit.

Usage under the maximum operating temperature, 50%Rh or less is required.

12.6 storing

In the case of storing for a long period of time for instance, for years for the purpose or replacement use, the following ways are recommended.

- Storage in a polyethylene bag with the opening sealed so as not to enter fresh air outside in it. And with no desiccant.
- Placing in a dark place where neither exposure to direct sunlight nor light's keeping the storage temperature range.
- Storing with no touch on polarizer surface by the anything else.
[It is recommended to store them as they have been contained in the inner container at the time of delivery from us

12.7 Safety

- It is recommendable to crash damaged or unnecessary LCD's into pieces and wash off liquid crystal by either of solvents such as acetone and ethanol, which should be burned up later.
- When any liquid leaked out of a damaged glass cell comes in contact with your hands, please wash it off well with soap and water

13. Precaution for Use

13.1

A limit sample should be provided by the both parties on an occasion when the both parties agreed its necessity. Judgment by a limit sample shall take effect after the limit sample has been established and confirmed by the both parties.

13.2

On the following occasions, the handing of problem should be decided through discussion and agreement between responsible of the both parties.

- When a question is arisen in this specification
- When a new problem is arisen which is not specified in this specifications
- When an inspection specifications change or operating condition change in customer is reported to AMSON TFT , and some problem is arisen in this specification due to the change
- When a new problem is arisen at the customer's operating set for sample evaluation in the customer site.

14. Packing Method

TBD.
