

Product Specification

	Model: XTPQ22SN04-01	Rev. No.	Issued Date.	Page.
		D	2017,06,02	1 / 23

Thin-Film-Transistor LCD Module Model:XTPQ22SN04-01

Acceptance

Approved and Checked by

Approved by	Checked by		Made by

Product Specification

	Model: XTPQ22SN04-01	Rev. No.	Issued Date.	Page.
		D	2017,06,02	3 / 23

1. General Description and Features

XTPQ22SN04-01 is a TM (Transmissive) type color active matrix TFT (Thin Film Transistor) liquid crystal display (LCD) that uses amorphous silicon TFT as a switching device.

This model is composed of a TFT-LCD module, a driver circuit and a back-light unit .

The resolution of a 2.2" contains 240RGBx320 dots and can display up to 262K colors. The following table described the features of XTPQ22SN04-01

LCD Module

Item	Specification	Unit
Screen Size	2.2inches	Diagona
Display Resolution	240RGB(H)x320(V)	Dot
Vision Area	33.84(H) x45.12 (V)	mm
Outline Dimension	41.04(W) x 56.45 (H) x 2.85 (D)	mm
Display Mode	Normally white/Transmissive	--
Pixel Arrangement	RGB-Vertical Stripe	--
Display Color	262K	--
Gray scale inversion Direction	12 o'clock	
Viewing Direction	6 o'clock	--
Drive IC	ILI9341V	--

Product Specification

	Model: XTPQ22SN04-01	Rev. No.	Issued Date.	Page.
		D	2017,06,02	4 / 23

2. Mechanical Information

Item		Min.	Typ.	Max.	Unit	Note
Module Size	Horizontal (H)	40.84	41.04	41.24	mm	--
	Vertical (V)	56.25	56.45	56.65	mm	(1)
	Thickness (T)	2.7	2.85	3.0	mm	(2)
Weight		--	N/A	--	g	--

Note (1) Not include FPC.

Refer to the Outline Dimension for further information.

(2) Back-light unit are included.

3. Electrical Specifications

3.1 Absolute Max. Ratings

3.1.1 Absolute Ratings of Environment

If the operating condition exceeds the following absolute maximum ratings, the TFT LCD module may be damaged permanently.

(Ta=25±2°C, V_{SS}=GND=0)

Item	Symbol	Min.	Max.	Unit	Note
Storage temperature	T _{STG}	-30	80	°C	(1)
Operating temperature	T _{OPR}	-20	70	°C	(1,2,3)

Note (1) 95 % RH Max. (40 °C ≥ Ta). Maximum wet-bulb temperature at 39 °C or less.
(Ta > 40 °C) No condensation.

Note (2) In case of below 0°, the response time of liquid crystal (LC) becomes slower and the color of panel becomes darker than normal one. Level of retardation depends on temperature, because of LC's character

Note (3) Only operation is guaranteed at operating temperature. Contrast, response time, another display quality are evaluated at +25°C.

Product Specification

	Model: XTPQ22SN04-01	Rev. No.	Issued Date.	Page.
		D	2017,06,02	5 / 23

3.2 Electrical Absolute Rating

3.2.1 TFT-LCD Module

(Voltage Referenced to VSS)

Item	Symbol	Value		Unit	Condition
		Min.	Max.		
Digital Power Supply Voltage	VDD	VSS-0.3	4.6	V	--

3.2.2 Back-Light Unit

(Ta=25±2°C)

Item	Symbol	Min.	Max.	Unit	Note
Forward current	I _f	--	30	mA	(1)
Reverse voltage	V _R	--	5.0	V	(1)

Note (1) Permanent damage to the device may occur if maximum values are exceeded or reverse voltage is loaded. Functional operation should be restricted to the conditions described under normal operating conditions.

Product Specification

	Model: XTPQ22SN04-01	Rev. No.	Issued Date.	Page.
		D	2017,06,02	6 / 23

4 Electrical Characteristics

4.1 TFT-LCD Module (DC Characteristics)

Item	Symbol	Value			Unit	Note
		Min.	Typ.	Max.		
Logic Power Supply Voltage	IOVCC	1.65	2.8	3.3	V	
Power Supply Voltage	V _{ci}	2.5	2.8	3.3	V	
Input High Threshold Voltage	V _{IH}	0.7 VDD	-	VDD	V	
Input Low Threshold Voltage	V _{IL}	0	-	0.3 VDD	V	
Power Supply Current	I _{CC}	-	6	20	mA	(1)
Power Consumption	P _L	-	--	--	mW	(1)

Note (1) The specified power consumption is under the conditions at VDD=2.8V , F_V=60Hz, where as a Power dissipation check pattern below is displayed.

Black Pattern / 0 Gray

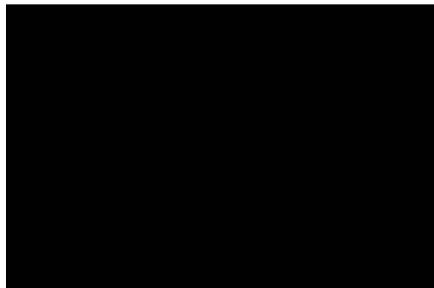

Active Area

Product Specification

	Model: XTPQ22SN04-01	Rev. No.	Issued Date.	Page.
		D	2017,06,02	7 / 23

4.2 Backlight Unit

The back-light system is an edge-lighting type with 3 white LEDs (Light Emitting Diode).

(Ta=25±2°C)

Item	Symbol	Value			Unit	Condition
		Min.	Typ.	Max.		
LED Voltage	V _F	3.0	3.1	3.4	V	
LED Current	I _F	-	45	-	mA	
Power Consumption	P _{BL}	-	139.5	-	mW	
Life time		-	25000	-	hours	

Note (1) Where I_F = 45mA, V_F = 3.1V, P_{BL} = V_F × I_F

Product Specification



Model: XTPQ22SN04-01

Rev. No.

Issued Date.

Page.

D

2017,06,02

8 / 23

5 Block Diagram

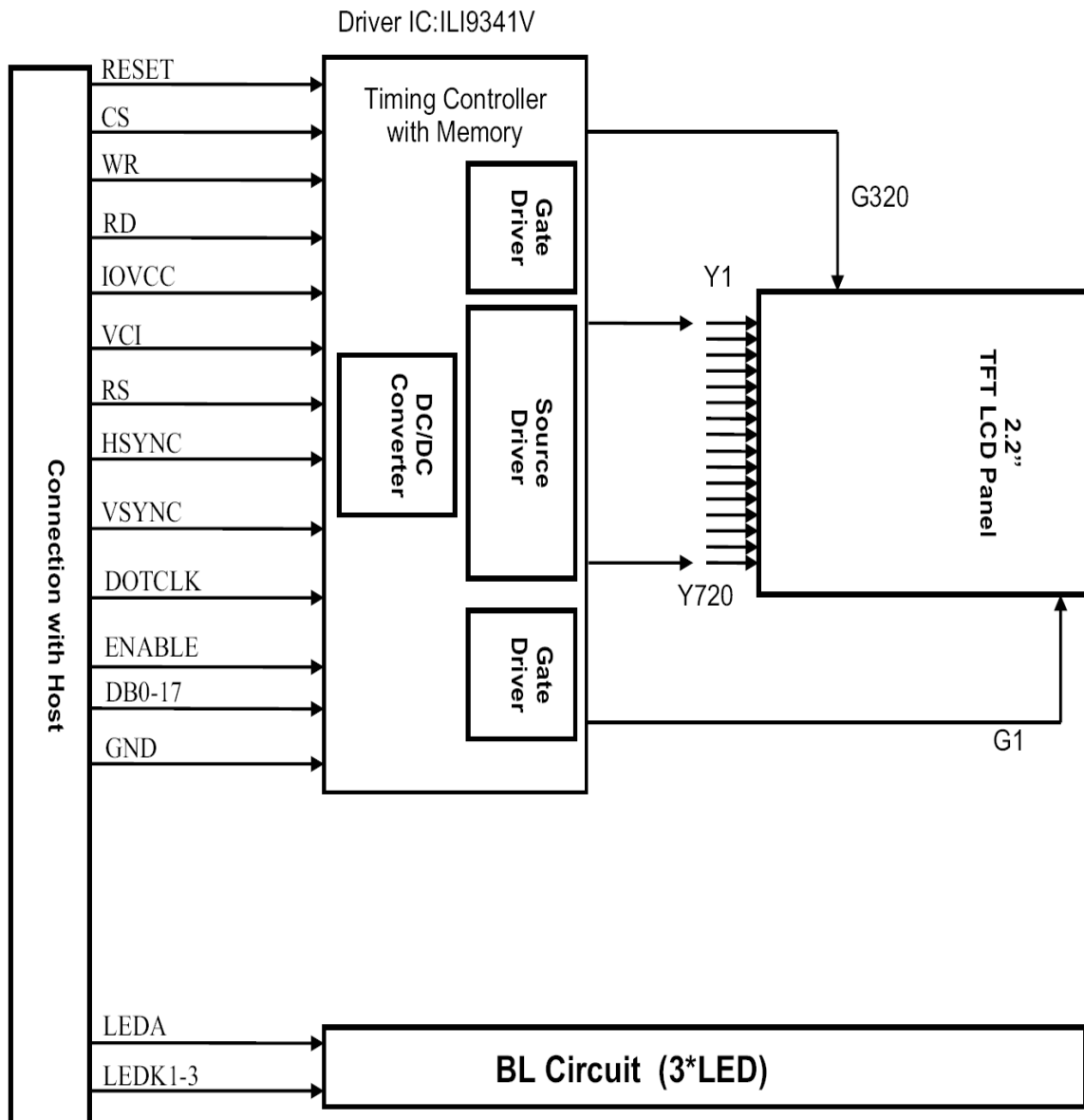

Product Specification



Model: XTPQ22SN04-01

Rev. No.

Issued Date.

Page.

D

2017,06,02

9 / 23

6 Input Terminal Pin Assignment

Pin No.	Symbol	Description
1	GND	Ground
2	IM0	Select the MCU interface mode
3	IM1	Select the MCU interface mode
4	IM2	Select the MCU interface mode
5	IM3	Select the MCU interface mode
6	RESET	Reset input terminal
7	VSYNC	Vertical sync input in RGB mode
8	HSYNC	Horizontal sync input in RGB mode
9	DOTCLK	Pixel clock input in RGB mode
10	ENABLE	Data enable input in RGB mode
11	DB17	Data bus
12	DB16	Data bus
13	DB15	Data bus
14	DB14	Data bus
15	DB13	Data bus
16	DB12	Data bus
17	DB11	Data bus
18	DB10	Data bus
19	DB9	Data bus
20	DB8	Data bus
21	DB7	Data bus
22	DB6	Data bus
23	DB5	Data bus
24	DB4	Data bus
25	DB3	Data bus
26	DB2	Data bus
27	DB1	Data bus
28	DB0	Data bus
29	SDI	Serial data input
30	RD	Read signal
31	WR	Serves as command or parameter select
32	RS	Select data or command
33	CS	Chip select
34	FMARK	Synchronize MPU to frame writing
35	IOVCC	Power supply
36	VCI	Power supply

Product Specification



Model: XTPQ22SN04-01

Rev. No.

Issued Date.

Page.

D

2017,06,02

10 / 23

37	GND	Ground
38	LEDA	LED+
39	LEDK1	LED-
40	LEDK2	LED-
41	LEDK3	LED-

Product Specification

	Model: XTPQ22SN04-01	Rev. No.	Issued Date.	Page.
		D	2017,06,02	11 / 23

7 Optical Characteristics

The following items are measured under stable conditions. The optical characteristics should be measured in a dark room or equivalent state with the methods.

Measuring equipment: BM-7A

Item	Symbol	Condition	Min	Type	Max	Unit	Note	
Brightness	B		200	--	--	cd/m ²		
Response time	T _r +T _f	θ=0° T=25°C	--	40	60	ms	.	
Contrast ratio	CR		250	350	--	--		
Color Gamut	NTSC %	--	--	48	--	%		
Luminance Uniformity	ΔL		--	80		%		
Color Chromaticity (CIE 1931)	White	W _x	θ=0° Normal Viewing Angle	0.213	0.255	0.353	--	BM-7A
		W _y		0.301	0.421	0.441		
Viewing Angle	Hor.	θ _R	--	60	70	--	Degree	
		θ _L		60	70	--		
	Ver.	θ _U		60	70	--		
		θ _D		40	50	--		

Product Specification

	Model: XTPQ22SN04-01	Rev. No.	Issued Date.	Page.
		D	2017,06,02	12 / 23

a. Test equipment setup

After stabilizing and leaving the panel alone shall be warmed up for the stable operation of LCM, the measurement should be executed. Measurement should be executed in a stable, windless, and dark room. Optical specifications are measured by Topcon BM-7(fast) with a viewing angle of 2° at a distance of 50cm and normal direction.

b. Definition of response time: Tr and Tf

The response time is defined as the following figure and shall be measured by switching the input signal for "black" and "white".

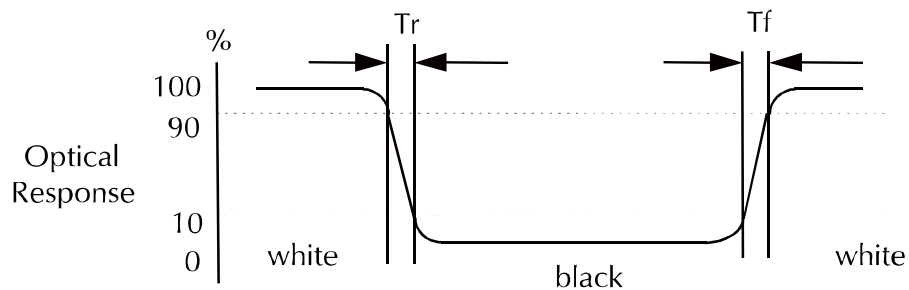

c. Definition of contrast ratio:

$$\text{Contrast Ratio (CR)} = \frac{\text{Brightness measured when LCD is at "white state"}}{\text{Brightness measured when LCD is at "black state"}}$$

d. Measured at the center area of the panel when all the input terminals of LCD panel are electrically opened.

Product Specification

	Model: XTPQ22SN04-01	Rev. No.	Issued Date.	Page.
		D	2017,06,02	13 / 23

e. View Angle

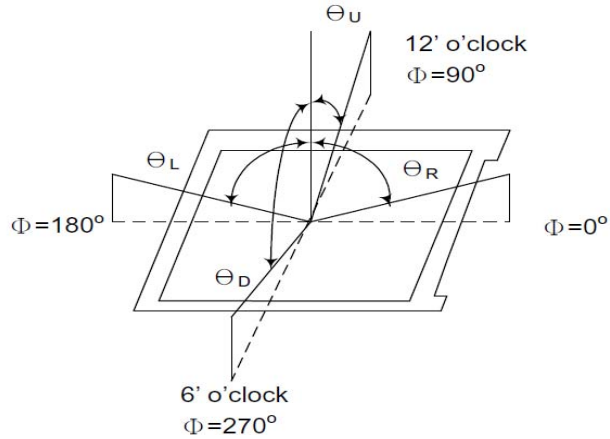

f. Definition of Luminance of White: Luminance of white at the center points

Light Source of Back-Light Unit	LED Type
---------------------------------	----------

g. Definition of White Uniformity

$$\text{White Uniformity} = \frac{\text{Min. luminance of white among 9-points}}{\text{Max. luminance of white among 9-points}} \times 100\%$$

h. The definition of Color Gamut -Color Chromaticity CIE 1931

Color coordinate of white & red, green, blue at center point.

$$\text{Color Gamut : NTSC(\%)} = (\text{RGB Triangle Area} / \text{NTSC Triangle Area}) \times 100$$

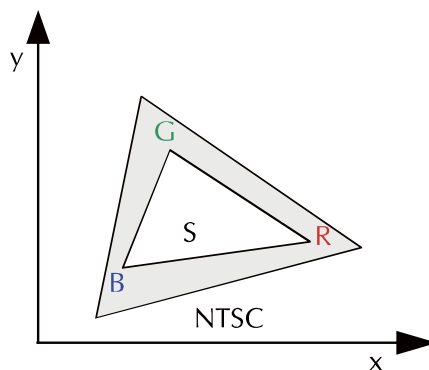

Product Specification



Model: XTPQ22SN04-01

Rev. No.

Issued Date.

Page.

D

2017,06,02

14 / 23

8 Interface Timing

8-1 RGB Interface

(VCI=2.5~3.2V, Ta=25°C)

Parameter	Description	Min	Max	Unit
tSYNCS	VSYNC/HSYNC setup time	15		ns
tSYNCH	VSYNC/HSYNC	15		ns
tENS	ENAB	15		ns
tENH	ENAB	15		ns
tPOS	Data	15		ns
tPDH	Data	15		ns
PWDH	DCLK high-level period	15		ns
PWDL	DCLK low-level period	15		ns
tCYCD	DCLK cycle time	100		ns
trgbr , trgbf	DCLK,HSYNC,VSYNC rise/fall		15	ns

Table 1.1 RGB Interface Characteristics

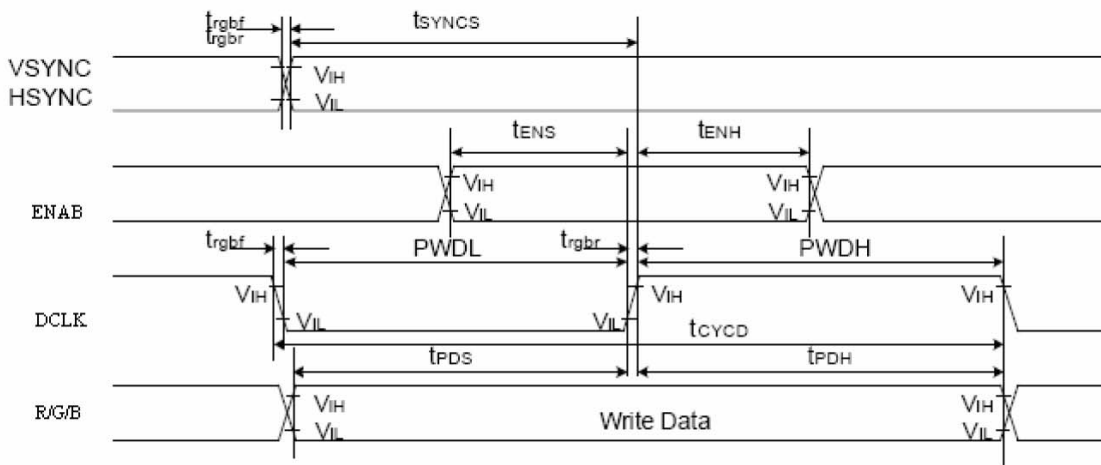

Fig.1-1 RGB Interface Timing

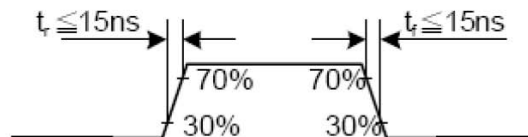

Fig.1-2 Input signal's rise and fall times

Product Specification



Model: XTPQ22SN04-01

Rev. No.

Issued Date.

Page.

D

2017,06,02

15 / 23

(VCI=2.5~3.2V, Ta=25°C)

Parameter	Symbol	Symbol	Min	Typ	Max	Unit
DCLK	DCLK frequency	fDCYC		5.64	10	MHz
	DCLK period	tDCYC	100	177.15		ns
HSYNC	Horizontal	Thd	240			DCLK
	1horizontalline	Th		310		
	Horizontal blank	Thb	56	60		
	Horizontal front porch	Thfp	2	10	16	
VSYNC	Vertical display area	Tvd	320			Line
	Vsync period time	Tv		328		
	Vsync blank	Tvb	2	4		
	Vsync Front porch	Tvfp	2	4		

Tab 1.2 Recommed Input Timing(DCLK,HSYNC,VSYNC,ENAB)

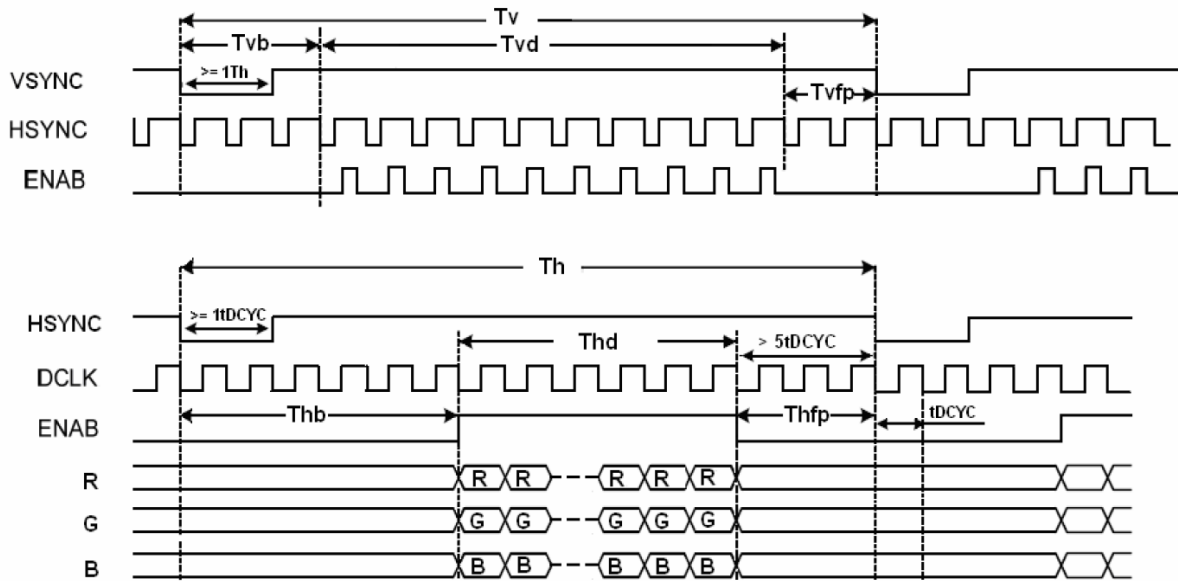



Fig.1-3 Recommed RGB Interface Timing

Product Specification

	Model: XTPQ22SN04-01	Rev. No.	Issued Date.	Page.
		D	2017,06,02	16 / 23

8-2 MCU Interface

8080-18bit Timing EXample:

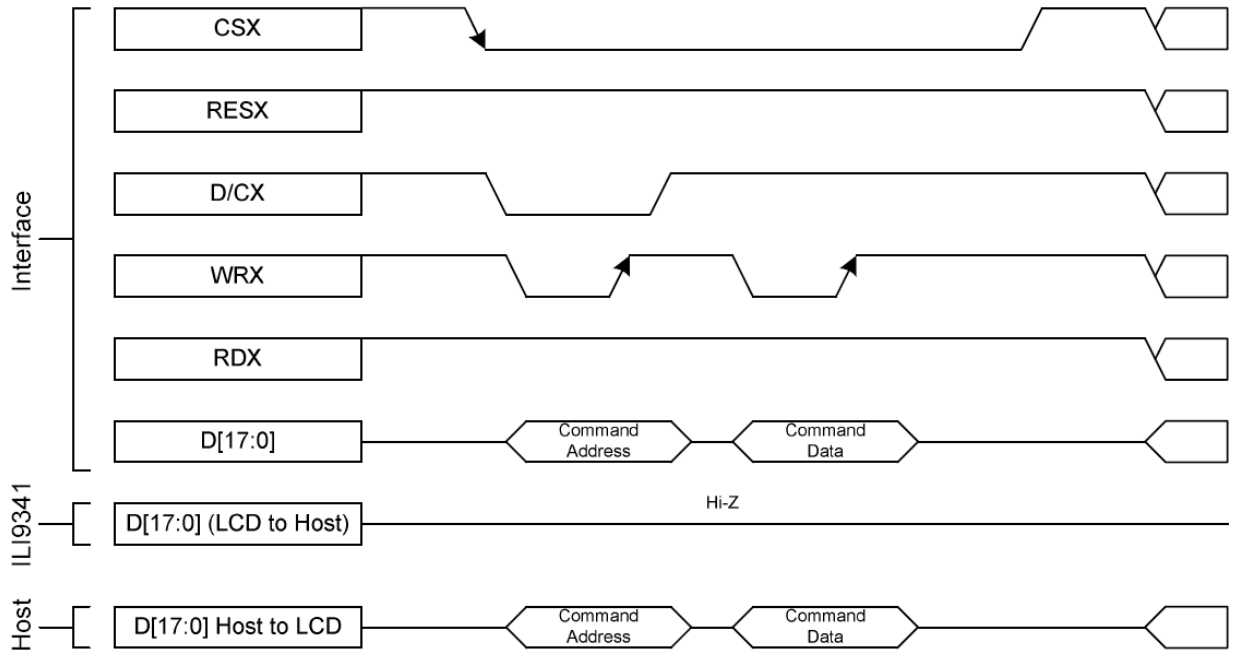

Signals on D[17:0], D/CX, RDX and WRX wires during CSX=" H" are ignored.

Product Specification

	Model: XTPQ22SN04-01	Rev. No.	Issued Date.	Page.
		D	2017,06,02	17 / 23

9. Reliability Condition for LCD

No change on display and in operation under the following test condition.

Condition: Unless otherwise specified, tests will be conducted under the following condition.

Temperature: $20 \pm 5^\circ\text{C}$

Humidity: $65 \pm 5\% \text{RH}$

Tests will be not conducted under functioning state.

No.	Parameter	Condition	Notes
1	High Temperature Operating	$70^\circ\text{C} \pm 2^\circ\text{C}$, 240hrs (Operation state)	--
2	Low Temperature Operating	$-20^\circ\text{C} \pm 2^\circ\text{C}$, 240hrs (Operation state)	--
3	High Temperature Storage	$80^\circ\text{C} \pm 2^\circ\text{C}$, 240hrs	--
4	Low Temperature Storage	$-30^\circ\text{C} \pm 2^\circ\text{C}$, 240hrs	--
5	High Temperature and High Humidity Operation Test	$60^\circ\text{C} \pm 2^\circ\text{C}$, 90%, 240hrs	--
6	Vibration Test	Total fixed amplitude: 1.5mm Vibration Frequency: 10~55Hz One cycle 60 seconds to 3 direction of X, Y, Z each 15 minutes.	--

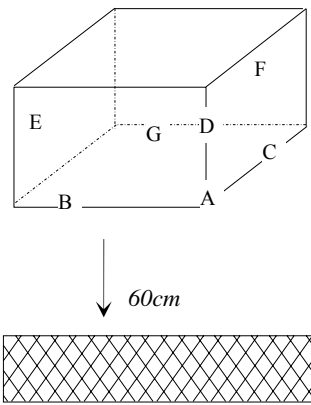
7.	Drop Test	<p>To be measured after dropping from 60cm high on the concrete surface in packing state.</p> <div style="text-align: center;">  </div> <p style="text-align: right; margin-right: 20px;"> <i>Dropping method corner dropping</i> <i>A corner: once</i> <i>Edge dropping</i> <i>B, C, D edge: once</i> <i>Face dropping</i> <i>E, F, G face: once</i> </p>	--
----	-----------	--	----

Notes: 1. No dew condensation to be observed.

2. The function test shall be conducted after 4 hours storage at the normal temperature and humidity after removed from the test chamber.

Product Specification



Model: XTPQ22SN04-01

Rev. No.

Issued Date.

Page.

D

2017,06,02

18 / 23

10. Dimensional outlines

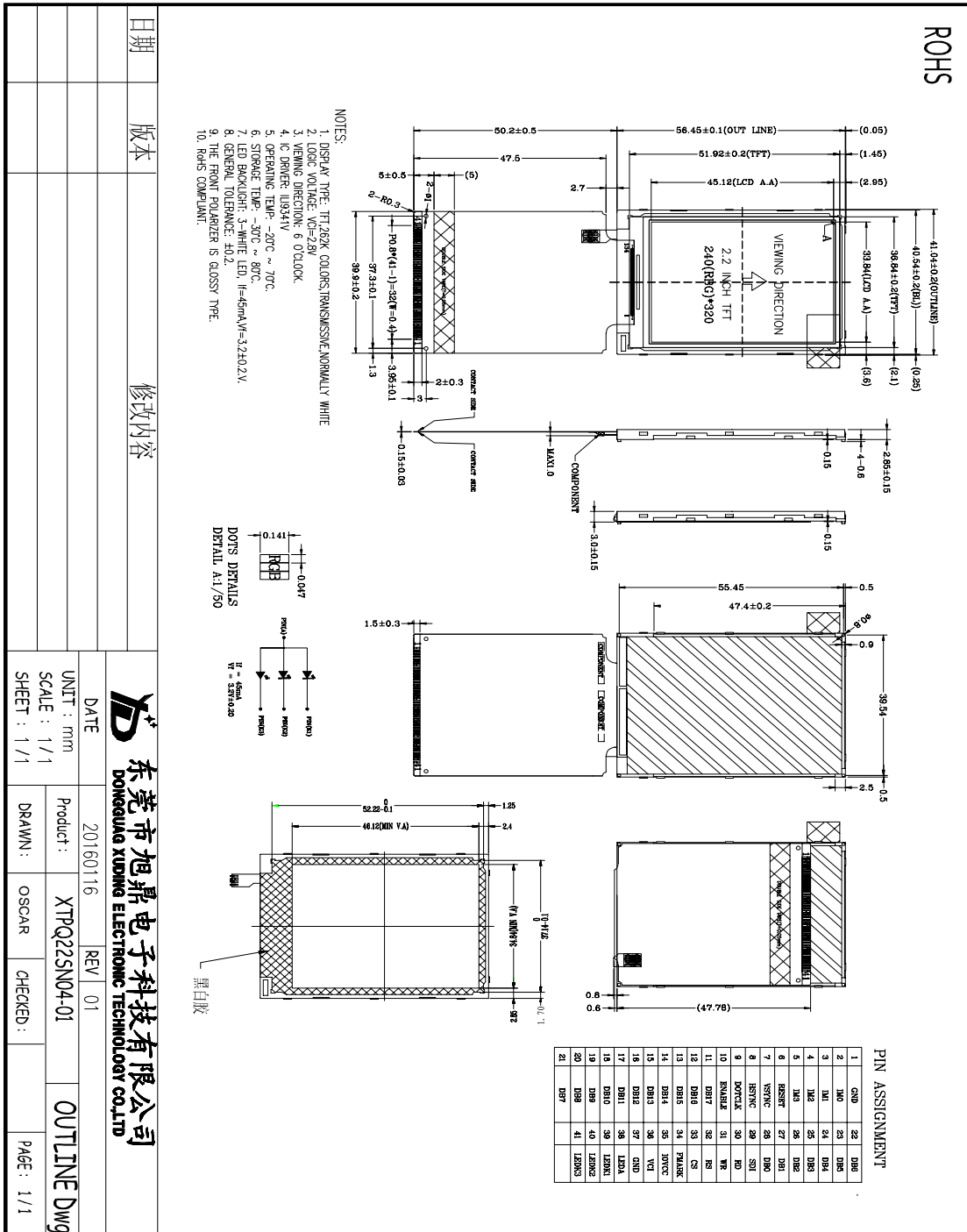

日期 版本 修改内容

DATE
UNIT : mm
SCALE : 1/1
SHEET : 1/1

东莞市旭鼎电子科技有限公司
DONGGUAN XUDING ELECTRONIC TECHNOLOGY CO.,LTD

20160116 REV 01
Product : XTPQ22SN04-01
DRAWN : OSCAR
CHECKED :

OUTLINE DWG
PAGE : 1/1

Product Specification

	Model: XTPQ22SN04-01	Rev. No.	Issued Date.	Page.
		D	2017,06,02	19 / 23

9 Incoming Inspection Standards

11.1 VISUAL & FUNCTION INSPECTION STANDARD

11.1.1 Inspection conditions

Inspection performed under the following conditions is recommended.

Temperature : $25 \pm 5^{\circ}\text{C}$

Humidity : $65\% \pm 10\% \text{RH}$

Viewing Angle : Normal viewing Angle.

Illumination: Single fluorescent lamp (300 to 700Lux)

Viewing distance: 30-50cm

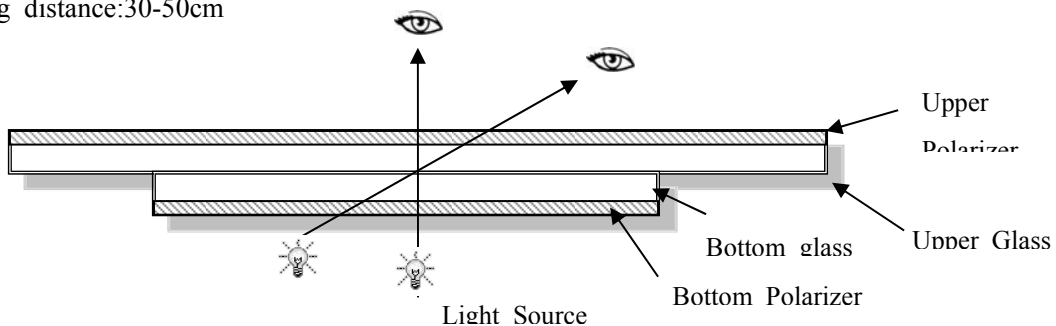

11.1.2 Definition

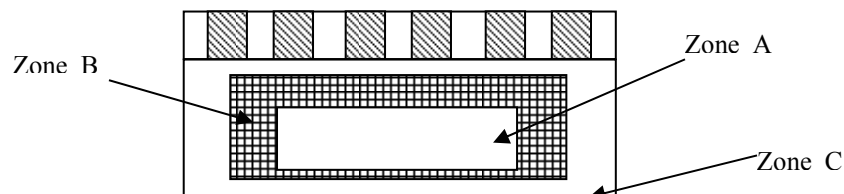

Zone A : Effective Viewing Area (Character or Digit can be seen)

Zone B : Viewing Area except Zone A

Zone C : Outside (Zone A + Zone B) which can not be seen after assembly by customer .)

Note:

As a general rule, visual defects in Zone C can be ignored when it doesn't effect product function

or appearance after assembly by customer.

11.1.3 Sampling Plan

Product Specification				
	Model: XTPQ22SN04-01	Rev. No.	Issued Date.	Page.
		D	2017,06,02	20 / 23

According to GB/T 2828-2003 ; , normal inspection, Class II

AQL:

Major defect	Minor defect
0.65	1.5

LCD: Liquid Crystal Display , TP: Touch Panel , LCM: Liquid Crystal Module

No	Items to be inspected	Criteria	Classification of defects
1	Functional defects	1) No display, Open or miss line 2) Display abnormally, Short 3) Backlight no lighting, abnormal lighting. 4) TP no function	Major
2	Missing	Missing component	
3	Outline dimension	Overall outline dimension beyond the drawing is not allowed	
4	Color tone	Color unevenness, refer to limited sample	Minor
5	Soldering appearance	Good soldering , Peeling off is not allowed.	
6	LCD/Polarizer/TP	Black/White spot/line, scratch, crack, etc.	

11.1.4 Criteria (Visual)

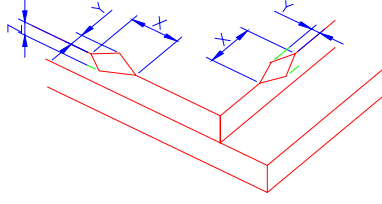
Number	Items	Criteria(mm)						
1.0 LCD Crack/Broken	(1) The edge of LCD broken	 <table border="1" data-bbox="845 1765 1391 1921"> <thead> <tr> <th>X</th> <th>Y</th> <th>Z</th> </tr> </thead> <tbody> <tr> <td>≤3.0mm</td> <td><Inner border line of the seal</td> <td>≤T</td> </tr> </tbody> </table>	X	Y	Z	≤3.0mm	<Inner border line of the seal	≤T
X	Y	Z						
≤3.0mm	<Inner border line of the seal	≤T						
NOTE: X: Length Y: Width								

Product Specification



Model: XTPQ22SN04-01

Rev. No.

Issued Date.

Page.

D

2017,06,02

21 / 23

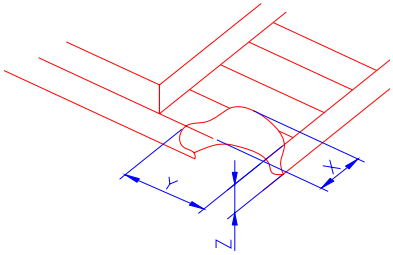
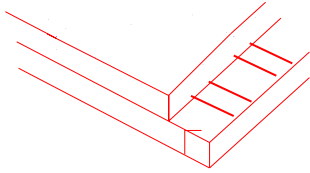
<p>Z: Height L: Length of ITO, T: Height of LCD</p>	<p>(2)LCD corner broken</p>	 <table border="1" data-bbox="906 757 1332 855"> <thead> <tr> <th>X</th> <th>Y</th> <th>Z</th> </tr> </thead> <tbody> <tr> <td>$\leq 3.0\text{mm}$</td> <td>$\leq L$</td> <td>$\leq T$</td> </tr> </tbody> </table>	X	Y	Z	$\leq 3.0\text{mm}$	$\leq L$	$\leq T$
	X	Y	Z					
$\leq 3.0\text{mm}$	$\leq L$	$\leq T$						
<p>(3) LCD crack</p>	 <p style="text-align: center;">Crack Not allowed</p>							

Product Specification



Model: XTPQ22SN04-01

Rev. No.

Issued Date.

Page.

D

2017,06,02

22 / 23

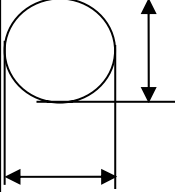
Number	Items	Criteria (mm)																							
2.0	Spot defect 	① light dot (LCD/TP/Polarizer black/white spot , light dot, pinhole, dent, stain)																							
		<table border="1"> <thead> <tr> <th rowspan="2">Zone Size (mm)</th> <th colspan="3">Acceptable Qty</th> </tr> <tr> <th>A</th> <th>B</th> <th>C</th> </tr> </thead> <tbody> <tr> <td>$\Phi \leq 0.10$</td> <td colspan="3">Ignore</td> </tr> <tr> <td>$0.10 < \Phi \leq 0.15$</td> <td colspan="3">3(distance $\geq 10\text{mm}$)</td> </tr> <tr> <td>$0.15 < \Phi \leq 0.2$</td> <td colspan="3">1</td> </tr> <tr> <td>$0.2 < \Phi$</td> <td colspan="3">0</td> </tr> </tbody> </table>	Zone Size (mm)	Acceptable Qty			A	B	C	$\Phi \leq 0.10$	Ignore			$0.10 < \Phi \leq 0.15$	3(distance $\geq 10\text{mm}$)			$0.15 < \Phi \leq 0.2$	1			$0.2 < \Phi$	0		
		Zone Size (mm)		Acceptable Qty																					
			A	B	C																				
		$\Phi \leq 0.10$	Ignore																						
	$0.10 < \Phi \leq 0.15$	3(distance $\geq 10\text{mm}$)																							
	$0.15 < \Phi \leq 0.2$	1																							
	$0.2 < \Phi$	0																							
	X $\Phi = (X+Y)/2$	② Dim spot (LCD/TP/Polarizer dim dot, light leakage, dark spot)																							
		<table border="1"> <thead> <tr> <th rowspan="2">Zone Size (mm)</th> <th colspan="3">Acceptable Qty</th> </tr> <tr> <th>A</th> <th>B</th> <th>C</th> </tr> </thead> <tbody> <tr> <td>$\Phi \leq 0.1$</td> <td colspan="3">Ignore</td> </tr> <tr> <td>$0.1 < \Phi \leq 0.2$</td> <td colspan="3">2(distance $\geq 10\text{mm}$)</td> </tr> <tr> <td>$0.2 < \Phi \leq 0.3$</td> <td colspan="3">1</td> </tr> <tr> <td>$\Phi > 0.3$</td> <td colspan="3">0</td> </tr> </tbody> </table>	Zone Size (mm)	Acceptable Qty			A	B	C	$\Phi \leq 0.1$	Ignore			$0.1 < \Phi \leq 0.2$	2(distance $\geq 10\text{mm}$)			$0.2 < \Phi \leq 0.3$	1			$\Phi > 0.3$	0		
		Zone Size (mm)		Acceptable Qty																					
			A	B	C																				
$\Phi \leq 0.1$		Ignore																							
$0.1 < \Phi \leq 0.2$		2(distance $\geq 10\text{mm}$)																							
$0.2 < \Phi \leq 0.3$		1																							
$\Phi > 0.3$	0																								
③ Polarizer accidented spot																									
<table border="1"> <thead> <tr> <th rowspan="2">Zone Size (mm)</th> <th colspan="3">Acceptable Qty</th> </tr> <tr> <th>A</th> <th>B</th> <th>C</th> </tr> </thead> <tbody> <tr> <td>$\Phi \leq 0.2$</td> <td colspan="3">Ignore</td> </tr> <tr> <td>$0.2 < \Phi \leq 0.5$</td> <td colspan="3">2(distance $\geq 10\text{mm}$)</td> </tr> <tr> <td>$\Phi > 0.5$</td> <td colspan="3">0</td> </tr> </tbody> </table>	Zone Size (mm)	Acceptable Qty			A	B	C	$\Phi \leq 0.2$	Ignore			$0.2 < \Phi \leq 0.5$	2(distance $\geq 10\text{mm}$)			$\Phi > 0.5$	0								
Zone Size (mm)		Acceptable Qty																							
	A	B	C																						
$\Phi \leq 0.2$	Ignore																								
$0.2 < \Phi \leq 0.5$	2(distance $\geq 10\text{mm}$)																								
$\Phi > 0.5$	0																								

Product Specification



Model: XTPQ22SN04-01

Rev. No.

Issued Date.

Page.

D

2017,06,02

23 / 23

	Line defect (LCD/TP /Polarizer black/white line, scratch, stain)	<table border="1" style="width: 100%; border-collapse: collapse;"> <thead> <tr> <th rowspan="2" style="width: 25%;">Width(mm)</th> <th rowspan="2" style="width: 25%;">Length(mm)</th> <th colspan="3" style="width: 50%;">Acceptable Qty</th> </tr> <tr> <th style="width: 16.6%;">A</th> <th style="width: 16.6%;">B</th> <th style="width: 16.6%;">C</th> </tr> </thead> <tbody> <tr> <td style="text-align: center;">$\Phi \leq 0.03$</td> <td style="text-align: center;">Ignore</td> <td colspan="3" style="text-align: center;">Ignore</td> </tr> <tr> <td style="text-align: center;">$0.03 < W \leq 0.05$</td> <td style="text-align: center;">$L \leq 3.0$</td> <td colspan="2" style="text-align: center;">$N \leq 2$</td> <td rowspan="2" style="text-align: center;">Ignore</td> </tr> <tr> <td style="text-align: center;">$0.05 < W \leq 0.08$</td> <td style="text-align: center;">$L \leq 2.0$</td> <td colspan="2" style="text-align: center;">$N \leq 2$</td> </tr> <tr> <td style="text-align: center;">$0.08 < W$</td> <td colspan="4" style="text-align: center;">Define as spot defect</td> </tr> </tbody> </table>	Width(mm)	Length(mm)	Acceptable Qty			A	B	C	$\Phi \leq 0.03$	Ignore	Ignore			$0.03 < W \leq 0.05$	$L \leq 3.0$	$N \leq 2$		Ignore	$0.05 < W \leq 0.08$	$L \leq 2.0$	$N \leq 2$		$0.08 < W$	Define as spot defect			
Width(mm)	Length(mm)	Acceptable Qty																											
		A	B	C																									
$\Phi \leq 0.03$	Ignore	Ignore																											
$0.03 < W \leq 0.05$	$L \leq 3.0$	$N \leq 2$		Ignore																									
$0.05 < W \leq 0.08$	$L \leq 2.0$	$N \leq 2$																											
$0.08 < W$	Define as spot defect																												
3.0	Polarizer bubble	<table border="1" style="width: 100%; border-collapse: collapse;"> <thead> <tr> <th rowspan="2" style="width: 25%;">Zone Size (mm)</th> <th colspan="3" style="width: 75%;">Acceptable Qty</th> </tr> <tr> <th style="width: 25%;">A</th> <th style="width: 25%;">B</th> <th style="width: 25%;">C</th> </tr> </thead> <tbody> <tr> <td style="text-align: center;">$\Phi < 0.2$</td> <td colspan="3" style="text-align: center;">Ignore</td> </tr> <tr> <td style="text-align: center;">$0.2 < \Phi < 0.4$</td> <td colspan="3" style="text-align: center;">2 (distance $\geq 10\text{mm}$)</td> </tr> <tr> <td style="text-align: center;">$0.4 < \Phi < 0.6$</td> <td colspan="3" style="text-align: center;">1</td> </tr> <tr> <td style="text-align: center;">$0.6 < \Phi$</td> <td colspan="3" style="text-align: center;">0</td> </tr> </tbody> </table>	Zone Size (mm)	Acceptable Qty			A	B	C	$\Phi < 0.2$	Ignore			$0.2 < \Phi < 0.4$	2 (distance $\geq 10\text{mm}$)			$0.4 < \Phi < 0.6$	1			$0.6 < \Phi$	0						
Zone Size (mm)	Acceptable Qty																												
	A	B	C																										
$\Phi < 0.2$	Ignore																												
$0.2 < \Phi < 0.4$	2 (distance $\geq 10\text{mm}$)																												
$0.4 < \Phi < 0.6$	1																												
$0.6 < \Phi$	0																												
4.0	SMT	According to IPC-A-610C class II standard . Function defect and missing part are major defect ,the others are minor defect.																											