

Dongguan xu ding electronics technology co., LTD



Model: XTPQ28SN11-02

Rev. No.

Issued Date.

Page.

A

2018,07,13

1 / 17

**Thin-Film-Transistor LCD Module
Model: XTPQ28SN11-02**

Acceptance

Approved and Checked by

Approved by	Checked by		Made by

Dongguan xu ding electronics technology co., LTD

	Model: XTPQ28SN11-02	Rev. No.	Issued Date.	Page.
		A	2018,07,13	2 / 17

Revise Records

Rev.	Date	Contents	Written	Approved
A	2018/07/13	Preliminary Specification	KLUADE	OSCAR

Special Notes

Note1.	
Note2.	
Note3.	
Note4.	
Note5.	

Dongguan xu ding electronics technology co., LTD

	Model: XTPQ28SN11-02	Rev. No.	Issued Date.	Page.
		A	2018,07,13	3 / 17

1.General Description and Features

XTPQ28SN11-02 is a TM (Transmissive) type color active matrix TFT (Thin Film Transistor) liquid crystal display (LCD) that uses amorphous silicon TFT as a switching device. This model is composed of a TFT-LCD module, a driver circuit and a back-light unit . The resolution of a 2.8" contains 240RGBx320 dots and can display up to 65K colors. The following table described the features of XTPQ28SN11-02.

LCD Module

Item	Specification	Unit
Screen Size	2.8inches	Diagona
Display Resolution	240RGB(H)x320(V)	Dot
Active Area	43.2 (H) x 57.6 (V)	mm
Outline Dimension	50.00(W) x69.20(H) x2.40 (D)	mm
Display Mode	Normally white/Transmissive	--
Pixel Arrangement	RGB-Vertical Stripe	--
Display Color	65.5K	--
Gray scale inversion Direction	12 o'clock	
Viewing Direction	6 o'clock	--
Drive IC	ST7789V	--
Surface luminance	270 cd/m ²	

Dongguan xu ding electronics technology co., LTD

	Model: XTPQ28SN11-02	Rev. No.	Issued Date.	Page.
		A	2018,07,13	4 / 17

2.Mechanical Information

Item		Min.	Typ.	Max.	Unit	Note
Module Size	Horizontal (H)	--	50.00	--	mm	--
	Vertical (V)	--	69.20	--	mm	(1)
	Thickness (T)	--	2.40	--	mm	(2)
Weight		--	N/A	--	g	--

Note (1) Not include FPC.

Refer to the Outline Dimension for further information.

(2) Back-light unit are included.

3.Electrical Specifications

3.1 Absolute Max. Ratings

3.1.1 Absolute Ratings of Environment

If the operating condition exceeds the following absolute maximum ratings, the TFT LCD module may be damaged permanently.

(Ta=25±2°C, V_{SS}=GND=0)

Item	Symbol	Min.	Max.	Unit	Note
Storage temperature	T _{STG}	-30	80	°C	(1)
Operating temperature	T _{OPR}	-20	70	°C	(1,2,3)

Note (1) 95 % RH Max. (40 °C ≥ Ta). Maximum wet-bulb temperature at 39 °C or less. (Ta > 40 °C)
No condensation.

Note (2) In case of below 0°, the response time of liquid crystal (LC) becomes slower and the color of panel becomes darker than normal one. Level of retardation depends on temperature, because of LC's character

Note (3) Only operation is guaranteed at operating temperature. Contrast, response time, another display quality are evaluated at +25°C.

Dongguan xu ding electronics technology co., LTD

	Model: XTPQ28SN11-02	Rev. No.	Issued Date.	Page.
		A	2018,07,13	5 / 17

3.2 Electrical Absolute Rating

3.2.1 TFT-LCD Module

(Voltage Referenced to VSS)

Item	Symbol	Value		Unit	Condition
		Min.	Max.		
Digital Power Supply Voltage	VDD	VSS-0.3	5.0	V	--

3.2.2 Back-Light Unit

(Ta=25±2°C)

Item	Symbol	Min.	Max.	Unit	Note
current	I _F	--	30	mA	(1)
voltage	V _R	--	5.0	V	(1)

Note (1) Permanent damage to the device may occur if maximum values are exceeded or reverse voltage is loaded. Functional operation should be restricted to the conditions described under normal operating conditions.

4 Electrical Characteristics

4.1 Backlight Unit

The back-light system is an edge-lighting type with six white LEDs (Light Emitting Diode).

(Ta=25±2°C)

Item	Symbol	Value			Unit	Condition
		Min.	Typ.	Max.		
LED Voltage	V _F	2.8	3.1	3.4	V	
LED Current	I _F	-	60		mA	
Power Consumption	P _{BL}	-	-	-	mW	

Note (1) Where I_F = 60mA, V_F = 3.1V P_{BL} = V_F × I_F

Dongguan xu ding electronics technology co., LTD

	Model: XTPQ28SN11-02	Rev. No.	Issued Date.	Page.
		A	2018,07,13	6 / 17

5 Input Terminal Pin Assignment

5-1.LCM

PIN.NO	SYMBOL	I/O/P	FUNCTION	REMARK
1	VCC	P	POWER SUPPLY	
2	GND	P	GROUND	
3	A	P	POWER FOR BACKLIHT(ANODE)	
4	RESET	I	This signal will reset the device and it must be applied to properly initialize the chip. -Signal is active low.	
5	CS	I	Chip selection pin. -Low enable.-High disable.	
6	RS	I	Display data/command selection pin in parallel interface.	
7	WR	I	WRITE ENABLE IN MCU PARALLEL INTERFACE	
8	RD	I	READ ENABLE IN 8080 MCU PARALLEL INTERFACE	
9~24	D0-D15	I/O	DB[17:0] are used as MCU parallel interface data bus. 8-bit I/F: when IM3:0, DB[7:0] are used; when IM3:1, DB[17:10] are used. 9-bit I/F: when IM3:0, DB[8:0] are used; when IM3:1, DB[17:9] are used. 16-bit I/F: when IM3:0, DB[15:0] are used; when IM3:1, DB[17:10] and DB[8:1] are used. 18-bit I/F: DB[17:0] are used. -DB[17:0] are used as RGB interface data bus. 6-bit RGB I/F: DB[5:0] are used. 16-bit RGB I/F: DB[17:13], DB[11:1] are used. 18-bit RGB I/F: DB[17:0] are used. -If not used, please fix this pin at VDDI or DGND	

Dongguan xu ding electronics technology co., LTD

	Model: XTPQ28SN11-02	Rev. No.	Issued Date.	Page.
		A	2018,07,13	7 / 17

6 LCD Optical Characteristics

Item	Symbol	Condition	Min	Type	Max	Unit	Note	
Brightness	B		240	270	--	cd/m ²		
Response time	T _r , T _f	θ=0°	--	16	--	ms	.	
Contrast ratio	CR	At optimized viewing angle	--	500	--	--		
Luminance Uniformity	ΔL		70	80		%		
Color Chromaticity (CIE 1931)	White	W _x	θ=0° Normal Viewing Angle	0.261	0.301	0.351	--	BM-7A
		W _y		0.287	0.337	0.387		
Viewing Angle (6H)	Hor.	θ _R	CR≥10	55	65	--	Degree	
		θ _L		55	65	--		
	Ver.	θ _U		50	60	--		
		θ _D		40	50	--		

	Model: XTPQ28SN11-02	Rev. No.	Issued Date.	Page.
		A	2018,07,13	8 / 17

Measuring Equipment

FPM520 of Westar Display technologies, INC., which utilized SR-3 for Chromaticity and BM-5A for other optical characteristics.

Note (1) Definition of Viewing Angle :

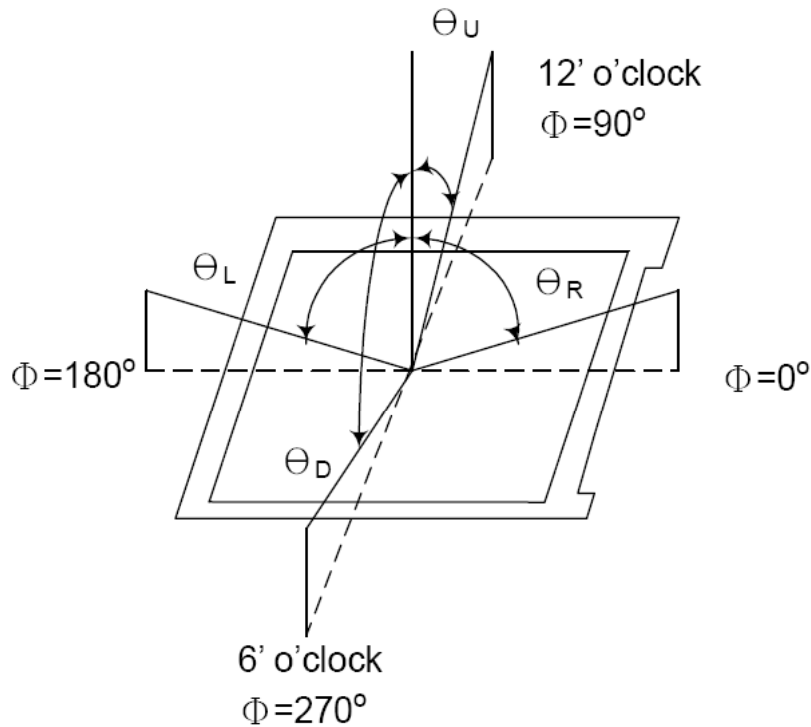

Note (2) Definition of Contrast Ratio(CR) :
measured at the center point of panel

$$CR = \frac{\text{Luminance with all pixels white}}{\text{Luminance with all pixels black}}$$

Dongguan xu ding electronics technology co., LTD

	Model: XTPQ28SN11-02	Rev. No.	Issued Date.	Page.
		A	2018,07,13	9 / 17

Note (3) Definition of Response Time : Sum of T_R and T_F

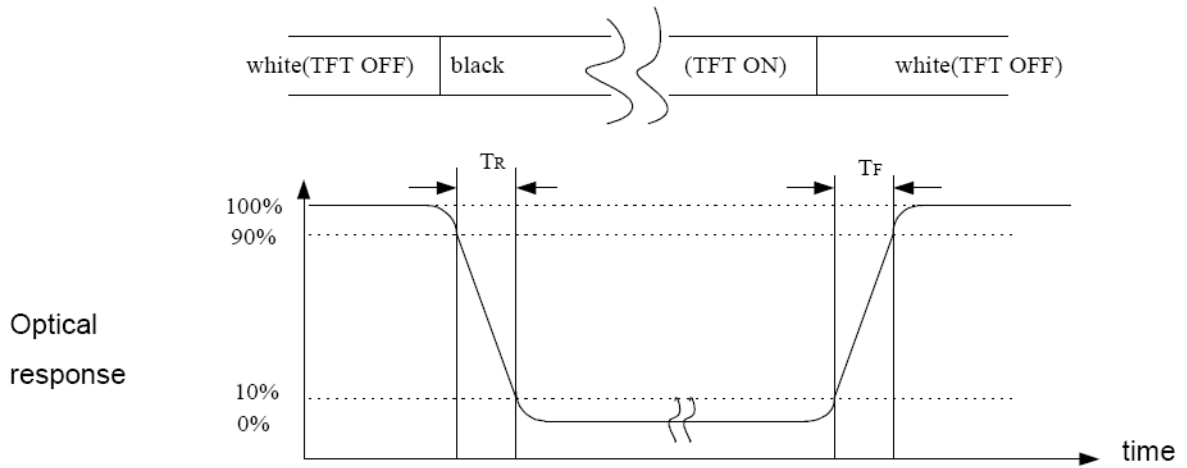

Note (4) Definition of optical measurement setup

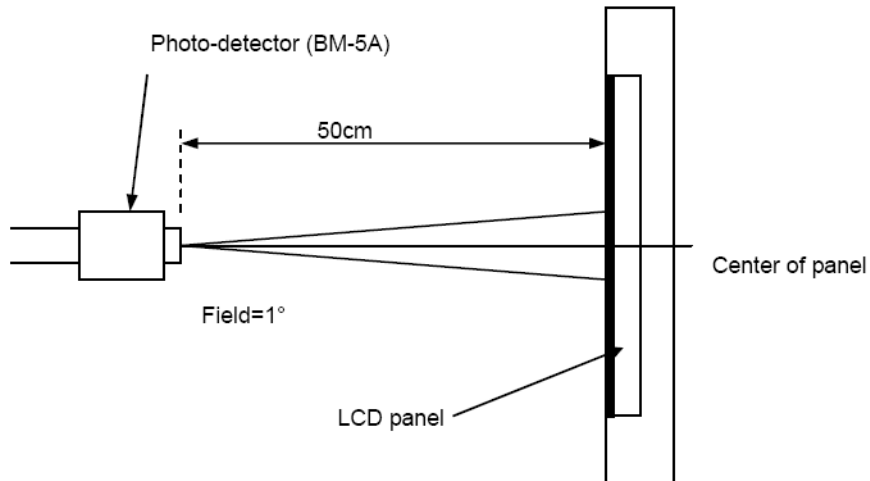

	Model: XTPQ28SN11-02	Rev. No.	Issued Date.	Page.
		A	2018,07,13	10 / 17

7 Interface Timing

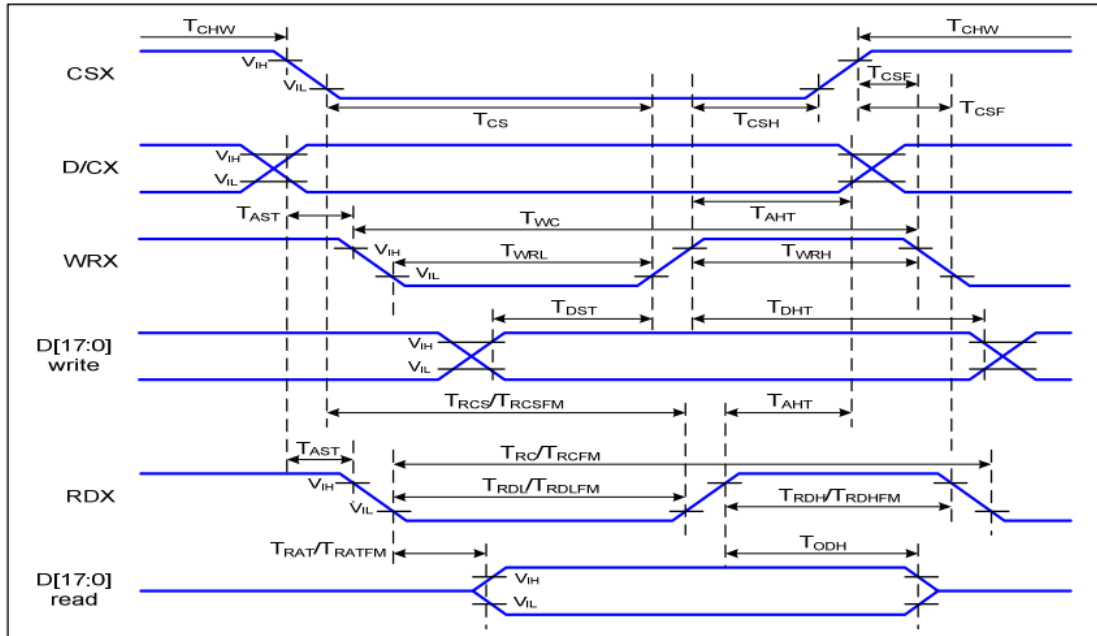



Figure 1 Parallel Interface Timing Characteristics (8080-Series MCU Interface)

VDDI=1.65 to 3.3V, VDD=2.4 to 3.3V, AGND=DGND=0V, Ta= -30 to 70 °C

Signal	Symbol	Parameter	Min	Max	Unit	Description
D/CX	T _{AST}	Address setup time	0		ns	-
	T _{AHT}	Address hold time (Write/Read)	10		ns	
CSX	T _{CHW}	Chip select "H" pulse width	0		ns	-
	T _{CS}	Chip select setup time (Write)	15		ns	
	T _{RCS}	Chip select setup time (Read ID)	45		ns	
	T _{RCSFM}	Chip select setup time (Read FM)	355		ns	
	T _{CSF}	Chip select wait time (Write/Read)	10		ns	
	T _{CSH}	Chip select hold time	10		ns	
WRX	T _{WC}	Write cycle	66		ns	-
	T _{WRH}	Control pulse "H" duration	15		ns	
	T _{WRL}	Control pulse "L" duration	15		ns	
RDX (ID)	T _{RC}	Read cycle (ID)	160		ns	When read ID data
	T _{RDH}	Control pulse "H" duration (ID)	90		ns	
	T _{RDL}	Control pulse "L" duration (ID)	45		ns	
RDX (FM)	T _{RCFM}	Read cycle (FM)	450		ns	When read from frame memory
	T _{RDHFM}	Control pulse "H" duration (FM)	90		ns	
	T _{RDLFM}	Control pulse "L" duration (FM)	355		ns	
D[17:0]	T _{DST}	Data setup time	10		ns	For CL=30pF

Dongguan xu ding electronics technology co., LTD

	Model: XTPQ28SN11-02	Rev. No.	Issued Date.	Page.
		A	2018,07,13	11 / 17

8 Reliability Condition for LCD

No change on display and in operation under the following test condition.

Condition: Unless otherwise specified, tests will be conducted under the following condition.

Temperature: 20±5° C Humidity: 65±5%RH

Tests will be not conducted under functioning state.

No.	Parameter	Condition	Notes
1	High Temperature Operating	70° C±2° C, 240hrs (Operation state)	--
2	Low Temperature Operating	-20° C±2° C, 240hrs (Operation state)	--
3	High Temperature Storage	80° C±2° C, 240hrs	--
4	Low Temperature Storage	-30° C±2° C, 240hrs	--
5	High Temperature and High Humidity Operation Test	60° C±2° C, 90%, 240hrs	--
6	Vibration Test	Total fixed amplitude: 1.5mm Vibration Frequency: 10-55Hz One cycle 60 seconds to 3 direction of X, Y, Z each 15 minutes.	--

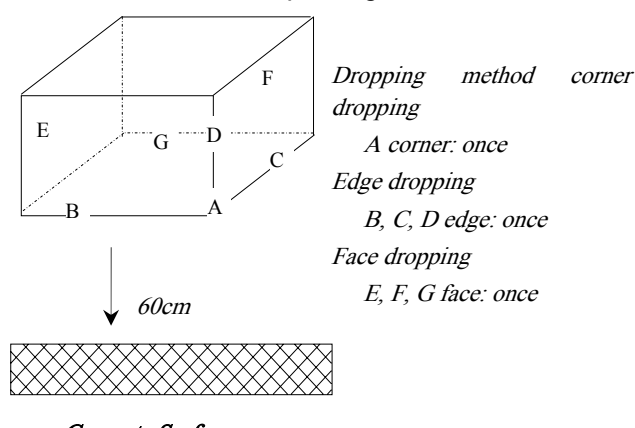
7.	Drop Test	<p>To be measured after dropping from 60cm high on the concrete surface in packing state.</p> <div style="text-align: center;">  </div>	--
----	-----------	---	----

- Notes:
1. No dew condensation to be observed.
 2. The function test shall be conducted after 4 hours storage at the normal temperature and humidity after removed from the test chamber.
 3. Vibration test will be conducted to the product itself without putting I in a container.

9 Dimensional outlines

Dongguan xu ding electronics technology co., LTD



Model: XTPQ28SN11-02

Rev. No.

Issued Date.

Page.

A

2018,07,13

12 / 17

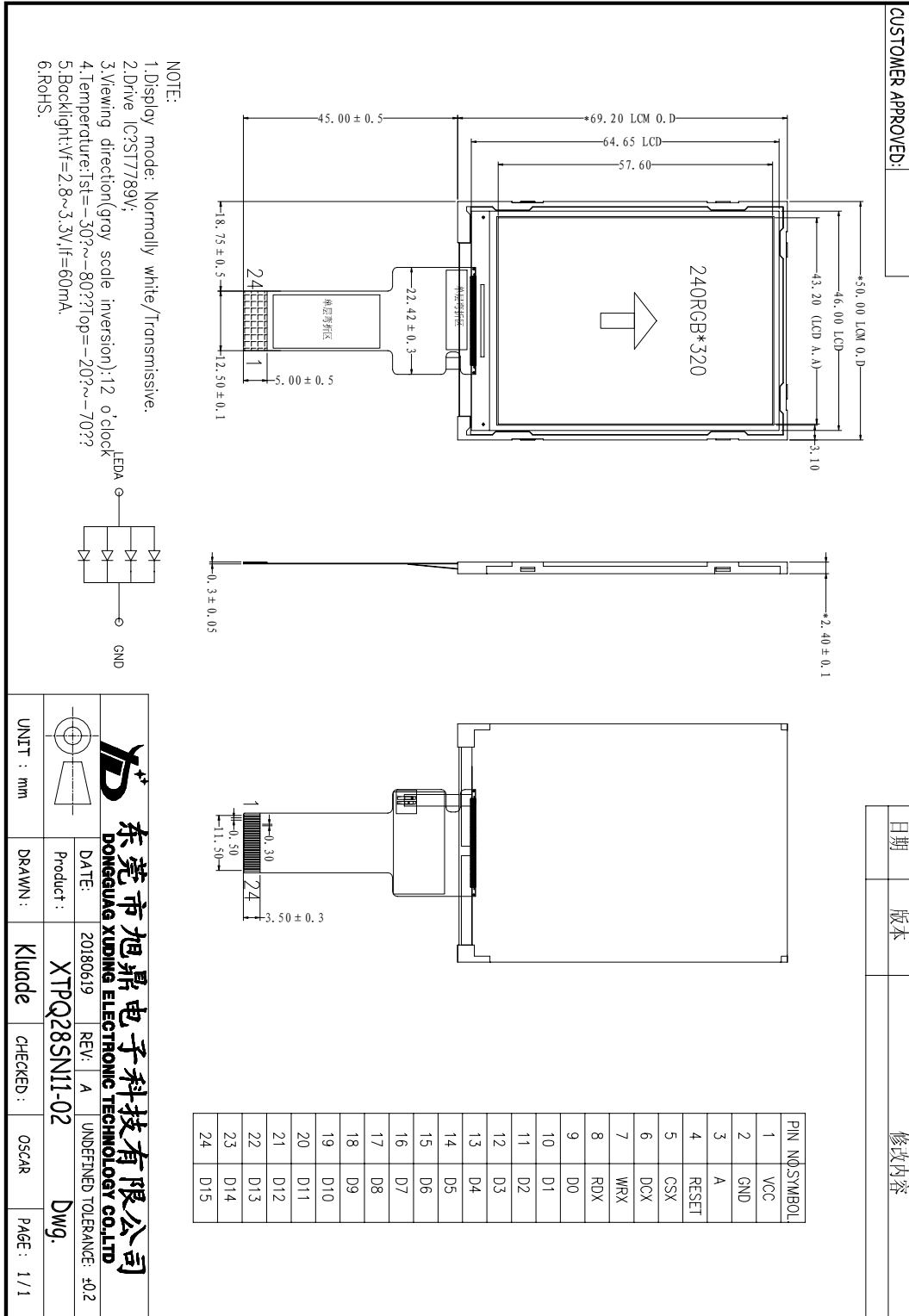

10 Incoming Inspection Standards

ADD:3F,SijiaLiuzhou Industrial Zone,76# Qinfeng Road Shijie Town,Dongguan City, Guangdong Province, China

Dongguan xu ding electronics technology co., LTD

	Model: XTPQ28SN11-02	Rev. No.	Issued Date.	Page.
		A	2018,07,13	13 / 17

10.1 VISUAL & FUNCTION INSPECTION STANDARD

10.1.1 Inspection conditions

Inspection performed under the following conditions is recommended.

Temperature : 25±5°C

Humidity : 65%±10%RH

Viewing Angle : Normal viewing Angle.

Illumination: Single fluorescent lamp (300 to 700Lux)

Viewing distance:30-50cm

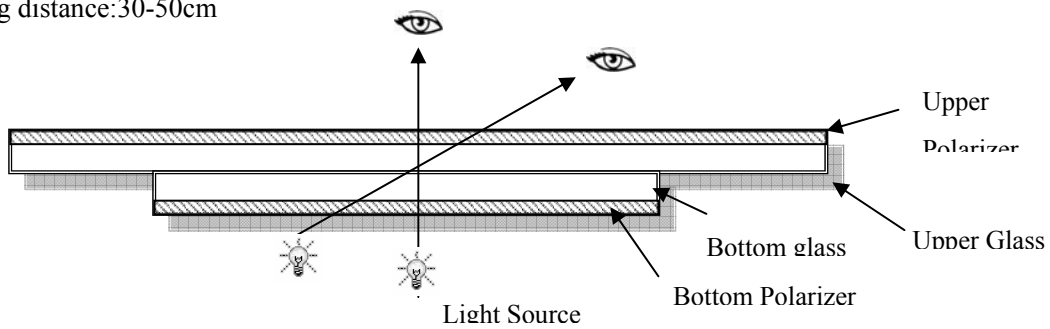

10.1.2 Definition

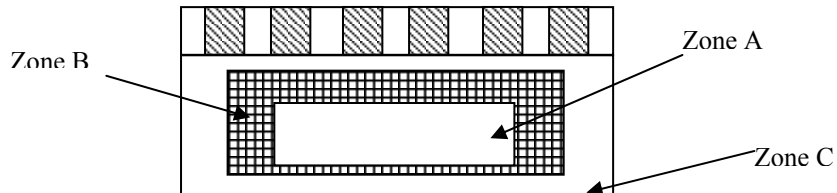

Zone A : Effective Viewing Area(Character or Digit can be seen)

Zone B : Viewing Area except Zone A

Zone C : Outside (Zone A+Zone B) which can not be seen after assembly by customer .)

Note:

As a general rule ,visual defects in Zone C can be ignored when it doesn't effect product function or appearance after assembly by customer.

10.1.3 Sampling Plan

According to GB/T 2828-2003 ; , normal inspection, Class II

AQL:

Major defect	Minor defect
--------------	--------------

Dongguan xu ding electronics technology co., LTD

	Model: XTPQ28SN11-02	Rev. No.	Issued Date.	Page.
		A	2018,07,13	14 / 17

0.65	1.5
------	-----

LCD: Liquid Crystal Display , TP: Touch Panel , LCM: Liquid Crystal Module

No	Items to be inspected	Criteria	Classification of defects
1	Functional defects	1) No display, Open or miss line 2) Display abnormally, Short 3) Backlight no lighting, abnormal lighting. 4) TP no function	Major
2	Missing	Missing component	
3	Outline dimension	Overall outline dimension beyond the drawing is not allowed	
4	Color tone	Color unevenness, refer to limited sample	Minor
5	Soldering appearance	Good soldering , Peeling off is not allowed.	
6	LCD/Polarizer/TP	Black/White spot/line, scratch, crack, etc.	

10.1.4 Criteria (Visual)

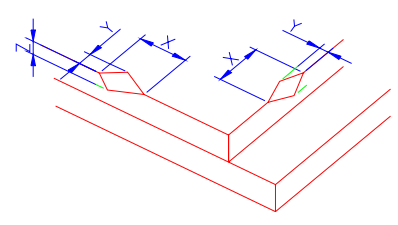
Number	Items	Criteria(mm)						
1.0 LCD Crack/Broken NOTE: X: Length Y: Width	(1) The edge of LCD broken	 <table border="1" style="margin: 10px auto; border-collapse: collapse;"> <tr> <td style="text-align: center;">X</td> <td style="text-align: center;">Y</td> <td style="text-align: center;">Z</td> </tr> <tr> <td style="text-align: center;">≤3.0mm</td> <td style="text-align: center;"><Inner border line of</td> <td style="text-align: center;">≤T</td> </tr> </table> <p style="text-align: center; margin-top: 5px;">the seal</p>	X	Y	Z	≤3.0mm	<Inner border line of	≤T
X	Y	Z						
≤3.0mm	<Inner border line of	≤T						

Dongguan xu ding electronics technology co., LTD



Model: XTPQ28SN11-02

Rev. No.	Issued Date.	Page.
A	2018,07,13	15 / 17

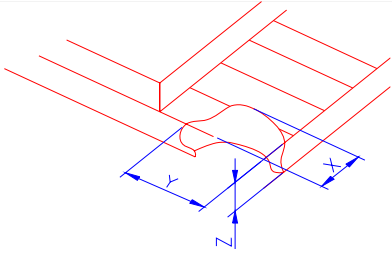
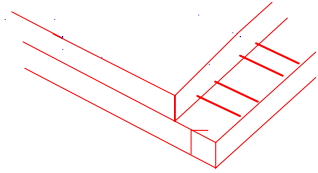
Z: Height L: Length of ITO, T: Height of LCD	(2)LCD corner broken	 <table border="1" data-bbox="906 701 1331 801"> <tr> <td align="center">X</td> <td align="center">Y</td> <td align="center">Z</td> </tr> <tr> <td align="center">≤3.0mm</td> <td align="center">≤L</td> <td align="center">≤T</td> </tr> </table>	X	Y	Z	≤3.0mm	≤L	≤T
	X	Y	Z					
≤3.0mm	≤L	≤T						
(3) LCD crack	 <p align="center">Crack Not allowed</p>							

Dongguan xu ding electronics technology co., LTD



Model: XTPQ28SN11-02

Rev. No.

Issued Date.

Page.

A

2018,07,13

16 / 17

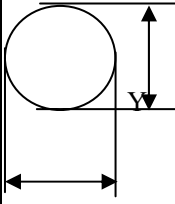
Number	Items	Criteria (mm)																																																																	
2.0	<p>Spot defect</p>  <p style="text-align: center;">$\Phi = (X+Y)/2$</p>	<p>① light dot (LCD/TP/Polarizer black/white spot , light dot, pinhole, dent, stain)</p> <table border="1" style="width: 100%; border-collapse: collapse;"> <thead> <tr> <th rowspan="2" style="text-align: center;">Zone Size (mm)</th> <th colspan="3" style="text-align: center;">Acceptable Qty</th> </tr> <tr> <th style="text-align: center;">A</th> <th style="text-align: center;">B</th> <th style="text-align: center;">C</th> </tr> </thead> <tbody> <tr> <td style="text-align: center;">$\Phi \leq 0.10$</td> <td colspan="3" style="text-align: center;">Ignore</td> </tr> <tr> <td style="text-align: center;">$0.10 < \Phi \leq 0.15$</td> <td colspan="3" style="text-align: center;">3(distance $\geq 10\text{mm}$)</td> </tr> <tr> <td style="text-align: center;">$0.15 < \Phi \leq 0.2$</td> <td colspan="3" style="text-align: center;">1</td> </tr> <tr> <td style="text-align: center;">$0.2 < \Phi$</td> <td colspan="3" style="text-align: center;">0</td> </tr> </tbody> </table> <p>② Dim spot (LCD/TP/Polarizer dim dot, light leakage、 dark spot)</p> <table border="1" style="width: 100%; border-collapse: collapse;"> <thead> <tr> <th rowspan="2" style="text-align: center;">Zone Size (mm)</th> <th colspan="3" style="text-align: center;">Acceptable Qty</th> </tr> <tr> <th style="text-align: center;">A</th> <th style="text-align: center;">B</th> <th style="text-align: center;">C</th> </tr> </thead> <tbody> <tr> <td style="text-align: center;">$\Phi \leq 0.1$</td> <td colspan="3" style="text-align: center;">Ignore</td> </tr> <tr> <td style="text-align: center;">$0.1 < \Phi \leq 0.2$</td> <td colspan="3" style="text-align: center;">2(distance $\geq 10\text{mm}$)</td> </tr> <tr> <td style="text-align: center;">$0.2 < \Phi \leq 0.3$</td> <td colspan="3" style="text-align: center;">1</td> </tr> <tr> <td style="text-align: center;">$\Phi > 0.3$</td> <td colspan="3" style="text-align: center;">0</td> </tr> </tbody> </table> <p>③ Polarizer accidented spot</p> <table border="1" style="width: 100%; border-collapse: collapse;"> <thead> <tr> <th rowspan="2" style="text-align: center;">Zone Size (mm)</th> <th colspan="3" style="text-align: center;">Acceptable Qty</th> </tr> <tr> <th style="text-align: center;">A</th> <th style="text-align: center;">B</th> <th style="text-align: center;">C</th> </tr> </thead> <tbody> <tr> <td style="text-align: center;">$\Phi \leq 0.2$</td> <td colspan="3" style="text-align: center;">Ignore</td> </tr> <tr> <td style="text-align: center;">$0.2 < \Phi \leq 0.5$</td> <td colspan="3" style="text-align: center;">2(distance $\geq 10\text{mm}$)</td> </tr> <tr> <td style="text-align: center;">$\Phi > 0.5$</td> <td colspan="3" style="text-align: center;">0</td> </tr> </tbody> </table>	Zone Size (mm)	Acceptable Qty			A	B	C	$\Phi \leq 0.10$	Ignore			$0.10 < \Phi \leq 0.15$	3(distance $\geq 10\text{mm}$)			$0.15 < \Phi \leq 0.2$	1			$0.2 < \Phi$	0			Zone Size (mm)	Acceptable Qty			A	B	C	$\Phi \leq 0.1$	Ignore			$0.1 < \Phi \leq 0.2$	2(distance $\geq 10\text{mm}$)			$0.2 < \Phi \leq 0.3$	1			$\Phi > 0.3$	0			Zone Size (mm)	Acceptable Qty			A	B	C	$\Phi \leq 0.2$	Ignore			$0.2 < \Phi \leq 0.5$	2(distance $\geq 10\text{mm}$)			$\Phi > 0.5$	0		
Zone Size (mm)	Acceptable Qty																																																																		
	A	B	C																																																																
$\Phi \leq 0.10$	Ignore																																																																		
$0.10 < \Phi \leq 0.15$	3(distance $\geq 10\text{mm}$)																																																																		
$0.15 < \Phi \leq 0.2$	1																																																																		
$0.2 < \Phi$	0																																																																		
Zone Size (mm)	Acceptable Qty																																																																		
	A	B	C																																																																
$\Phi \leq 0.1$	Ignore																																																																		
$0.1 < \Phi \leq 0.2$	2(distance $\geq 10\text{mm}$)																																																																		
$0.2 < \Phi \leq 0.3$	1																																																																		
$\Phi > 0.3$	0																																																																		
Zone Size (mm)	Acceptable Qty																																																																		
	A	B	C																																																																
$\Phi \leq 0.2$	Ignore																																																																		
$0.2 < \Phi \leq 0.5$	2(distance $\geq 10\text{mm}$)																																																																		
$\Phi > 0.5$	0																																																																		

Dongguan xu ding electronics technology co., LTD

	Model: XTPQ28SN11-02	Rev. No.	Issued Date.	Page.
		A	2018,07,13	17 / 17

	Line defect (LCD/TP /Polarizer black/white line, scratch, stain)	<table border="1" style="width: 100%; border-collapse: collapse; text-align: center;"> <thead> <tr> <th rowspan="2">Width(mm)</th> <th rowspan="2">Length(mm)</th> <th colspan="3">Acceptable Qty</th> </tr> <tr> <th>A</th> <th>B</th> <th>C</th> </tr> </thead> <tbody> <tr> <td>$\Phi \leq 0.03$</td> <td>Ignore</td> <td colspan="3">Ignore</td> </tr> <tr> <td>$0.03 < W \leq 0.05$</td> <td>$L \leq 3.0$</td> <td colspan="3">$N \leq 2$</td> </tr> <tr> <td>$0.05 < W \leq 0.08$</td> <td>$L \leq 2.0$</td> <td colspan="3">$N \leq 2$</td> </tr> <tr> <td>$0.08 < W$</td> <td colspan="4">Define as spot defect</td> </tr> </tbody> </table>	Width(mm)	Length(mm)	Acceptable Qty			A	B	C	$\Phi \leq 0.03$	Ignore	Ignore			$0.03 < W \leq 0.05$	$L \leq 3.0$	$N \leq 2$			$0.05 < W \leq 0.08$	$L \leq 2.0$	$N \leq 2$			$0.08 < W$	Define as spot defect			
Width(mm)	Length(mm)	Acceptable Qty																												
		A	B	C																										
$\Phi \leq 0.03$	Ignore	Ignore																												
$0.03 < W \leq 0.05$	$L \leq 3.0$	$N \leq 2$																												
$0.05 < W \leq 0.08$	$L \leq 2.0$	$N \leq 2$																												
$0.08 < W$	Define as spot defect																													
3.0	Polarizer Bubble	<table border="1" style="width: 100%; border-collapse: collapse; text-align: center;"> <thead> <tr> <th rowspan="2">Zone Size (mm)</th> <th colspan="3">Acceptable Qty</th> </tr> <tr> <th>A</th> <th>B</th> <th>C</th> </tr> </thead> <tbody> <tr> <td>$\Phi \leq 0.2$</td> <td colspan="3">Ignore</td> </tr> <tr> <td>$0.2 < \Phi < 0.4$</td> <td colspan="3">2(distance $\geq 10\text{mm}$)</td> </tr> <tr> <td>$0.4 < \Phi \leq 0.6$</td> <td colspan="3">1</td> </tr> <tr> <td>$0.6 < \Phi$</td> <td colspan="3">0</td> </tr> </tbody> </table>	Zone Size (mm)	Acceptable Qty			A	B	C	$\Phi \leq 0.2$	Ignore			$0.2 < \Phi < 0.4$	2(distance $\geq 10\text{mm}$)			$0.4 < \Phi \leq 0.6$	1			$0.6 < \Phi$	0							
Zone Size (mm)	Acceptable Qty																													
	A	B	C																											
$\Phi \leq 0.2$	Ignore																													
$0.2 < \Phi < 0.4$	2(distance $\geq 10\text{mm}$)																													
$0.4 < \Phi \leq 0.6$	1																													
$0.6 < \Phi$	0																													
4.0	SMT	According to IPC-A-610C class II standard . Function defect and missing part are major defect ,the others are minor defect.																												