

Product Specification				
	Model: XTPQ32NN01-01	Rev. No.	Issued Date.	Page.
		A	2016,04,27	1 / 19

### 3.2Thin-Film-Transistor LCD Module Model:XTPQ32NN01-01

Acceptance

Approved and Checked by

Approved by	Checked by		Made by

Revise Records



## Product Specification

	Model: XTPQ32NN01-01	Rev. No.	Issued Date.	Page.
		A	2016,04,27	3 / 19

### 1.General Description and Features

XTPQ32NN01-01 is a TM (Transmissive) type color active matrix TFT (Thin Film Transistor) liquid crystal display (LCD) that uses amorphous silicon TFT as a switching device. This model is composed of a TFT-LCD module, a driver circuit and a back-light unit . The resolution of a 3.2" contains 240RGBx320 dots and can display up to 262K colors. The following table described the features of XTPQ32NN01-01

#### LCD Module

Item	Specification	Unit
Screen Size	3.2inches	Diagona
Display Resolution	240RGB(H)x320(V)	Dot
Active Area	48.6 (H) x 64.8 (V)	mm
Outline Dimension	56.64(W) x 77.7(H) x 2.45 (D)	mm
Display Mode	Normally white/Transmissive	--
Pixel Arrangement	RGB-Vertical Stripe	--
Display Color	262K	--
Gray scale inversion Direction	6 o'clock	
Viewing Direction	12 o'clock	--
Drive IC	ILI9341C	--
Surface luminance	350 cd/m <sup>2</sup>	

Product Specification				
	Model: XTPQ32NN01-01	Rev. No.	Issued Date.	Page.
		A	2016,04,27	4 / 19

## 2.Mechanical Information

Item		Min.	Typ.	Max.	Unit	Note
Module Size	Horizontal (H)	--	56.64	--	mm	--
	Vertical (V)	--	77.7	--	mm	(1)
	Thickness (T)	--	2.45	--	mm	(2)
Weight		--	N/A	--	g	--

Note (1) Not include FPC.

Refer to the Outline Dimension for further information.

(2) Back-light unit are included.

## 3.Electrical Specifications

### 3.1 Absolute Max. Ratings

#### 3.1.1 Absolute Ratings of Environment

If the operating condition exceeds the following absolute maximum ratings, the TFT LCD module may be damaged permanently.

(Ta=25±2°C, V<sub>SS</sub>=GND=0)

Item	Symbol	Min.	Max.	Unit	Note
Operating temperature	T <sub>STG</sub>	-20	70	°C	(1)
Storage temperature	T <sub>OPR</sub>	-30	80	°C	(1,2,3)

Note (1) 95 % RH Max. ( 40 °C ≥ Ta ). Maximum wet-bulb temperature at 39 °C or less. (Ta > 40 °C)  
No condensation.

Note (2) In case of below 0°, the response time of liquid crystal (LC) becomes slower and the color of panel becomes darker than normal one. Level of retardation depends on temperature, because of LC's character

Note (3) Only operation is guaranteed at operating temperature. Contrast, response time, another display quality are evaluated at +25°C.

## Product Specification

Model: XTPQ32NN01-01	Rev. No.	Issued Date.	Page.
	A	2016,04,27	5 / 19

### 3.2 Electrical Absolute Rating

#### 3.2.1 TFT-LCD Module

(Voltage Referenced to VSS)

Item	Symbol	Value		Unit	Condition
		Min.	Max.		
Digital Power Supply Voltage	VDD	VSS-0.3	5.0	V	--

#### 3.2.2 Back-Light Unit

(Ta=25±2°C)

Item	Symbol	Min.	Max.	Unit	Note
Current (1LED)	I <sub>f</sub>	--	60	mA	(1)
voltage	V <sub>R</sub>	--	5	V	(1)

Note (1) Permanent damage to the device may occur if maximum values are exceeded or reverse voltage is loaded. Functional operation should be restricted to the conditions described under normal operating conditions.

## Product Specification

Model: XTPQ32NN01-01	Rev. No.	Issued Date.	Page.
	A	2016,04,27	6 / 19

### 4 Electrical Characteristics

#### 4.1 Backlight Unit

The back-light system is an edge-lighting type with six white LEDs (Light Emitting Diode).

(Ta=25±2°C)

Item	Symbol	Value			Unit	Condition
		Min.	Typ.	Max.		
LED Voltage	V <sub>F</sub>	-	3.2	3.4	V	
LED Current	I <sub>F</sub>	-	100	120	mA	
Power Consumption	P <sub>BL</sub>	-	-	-	mW	

Note (1) Where I<sub>F</sub> = 100A, V<sub>F</sub> = 3.2V P<sub>BL</sub> = V<sub>F</sub> × I<sub>F</sub>

## Product Specification

Model: XTPQ32NN01-01	Rev. No.	Issued Date.	Page.
	A	2016,04,27	7 / 19

### 5 Input Terminal Pin Assignment

PIN.N O	SYMBOL	I/O/P	FUNCTI	MEMARK
1	XL			
2	YU			
3	XR			
4	YD			
5	GND	P	POWER GROUND	
6	IOVCC	P	POWER SUPPLY	
7	VCI	I	High voltage power supply for analog circuit blocks (2.5 ~ 3.3 V)	
8	TE	O	Tearing effect output pin to synchronize MPU to frame writing, activated by S/W command. When this pin is not activated, this pin is low. If not used, open this pin.	
9	CS/SPL/CS	I	Chip select input pin ("Low" enable). This pin can be permanently fixed "Low" in MPU interface mode only. * note1,2	
10	DC/SPI/SC L	I	This pin is used to select "Data or Command" in the parallel interface or 4-wire 8-bit serial data interface. When DCX = '1', data is selected. When DCX = '0', command is selected. This pin is used serial interface clock in 3-wire 9-bit / 4-wire 8-bit serial data interface. If not used, this pin should be connected to VDDI or VSS.	
11	WR/SPI/DC	I	- 8080- I /8080- II system (WRX): Serves as a write signal and writes data at the rising edge. - 4-line system (D/CX): Serves as command or parameter select. Fix to VDDI level when not in use.	
12	RD	I	8080- I /8080- II system (RDX): Serves as a read signal and MCU read data at the rising edge. Fix to VDDI level when not in use.	
13	SPI/SDI/S DA	I /O	When IM[3] : Low, Serial in/out signal. When IM[3] : High, Serial input signal. The data is applied on the rising edge of the SCL signal. If not used, fix this pin at VDDI or VSS.	

## Product Specification

	Model: XTPQ32NN01-01	Rev. No.	Issued Date.	Page.
		A	2016,04,27	8 / 19

14	SPI SDO	O	Serial output signal. The data is outputted on the falling edge of the SCL signal. If not used, open this pin	
15	REST	I	This signal will reset the device and must be applied to properly initialize the chip. Signal is active low.	
16	GND	P	<b>POWER GROUND</b>	
17-32	DBO-DB15	I/O	18-bit parallel bi-directional data bus for MCU system and RGB interface mode <i>Fix to VSS level when not in use</i>	
33	A	P	<b>POWER FOR LED BACKLIHT(ANODE)</b>	
34	K	P	<b>POWER GROUND</b>	
35	K	P	<b>POWER GROUND</b>	
36	K	P	<b>POWER GROUND</b>	
37	GND	P	<b>POWER GROUND</b>	

38	IM0	I	<p style="text-align: center;">- Select the MCU interface mode</p> <table border="1" style="width: 100%; border-collapse: collapse;"> <thead> <tr> <th rowspan="2">IM3</th> <th rowspan="2">IM2</th> <th rowspan="2">IM1</th> <th rowspan="2">IM0</th> <th rowspan="2">MCU-Interface Mode</th> <th colspan="2">DB Pin in use</th> </tr> <tr> <th>Register/Content</th> <th>GRAM</th> </tr> </thead> <tbody> <tr> <td>0</td> <td>0</td> <td>0</td> <td>0</td> <td>80 MCU 8-bit bus interface I</td> <td>D[7:0]</td> <td>D[7:0]</td> </tr> <tr> <td>0</td> <td>0</td> <td>0</td> <td>1</td> <td>80 MCU 16-bit bus interface I</td> <td>D[7:0]</td> <td>D[15:0]</td> </tr> <tr> <td>0</td> <td>0</td> <td>1</td> <td>0</td> <td>80 MCU 9-bit bus interface I</td> <td>D[7:0]</td> <td>D[8:0]</td> </tr> <tr> <td>0</td> <td>0</td> <td>1</td> <td>1</td> <td>80 MCU 18-bit bus interface I</td> <td>D[7:0]</td> <td>D[17:0]</td> </tr> <tr> <td>0</td> <td>1</td> <td>0</td> <td>1</td> <td>3-wire 9-bit data serial interface I</td> <td colspan="2" style="text-align: center;">SDA: In/OUT</td> </tr> <tr> <td>0</td> <td>1</td> <td>1</td> <td>0</td> <td>4-wire 8-bit data serial interface I</td> <td colspan="2" style="text-align: center;">SDA: In/OUT</td> </tr> <tr> <td>1</td> <td>0</td> <td>0</td> <td>0</td> <td>80 MCU 16-bit bus interface II</td> <td>D[8:1]</td> <td>D[17:10], D[8:1]</td> </tr> <tr> <td>1</td> <td>0</td> <td>0</td> <td>1</td> <td>80 MCU 8-bit bus interface II</td> <td>D[17:10]</td> <td>D[17:10]</td> </tr> <tr> <td>1</td> <td>0</td> <td>1</td> <td>0</td> <td>80 MCU 18-bit bus interface II</td> <td>D[8:1]</td> <td>D[17:0]</td> </tr> <tr> <td>1</td> <td>0</td> <td>1</td> <td>1</td> <td>80 MCU 9-bit bus interface II</td> <td>D[17:10]</td> <td>D[17:9]</td> </tr> <tr> <td>1</td> <td>1</td> <td>0</td> <td>1</td> <td>3-wire 9-bit data serial interface II</td> <td colspan="2" style="text-align: center;">SDI: In SDO: Out</td> </tr> <tr> <td>1</td> <td>1</td> <td>1</td> <td>0</td> <td>4-wire 8-bit data serial interface II</td> <td colspan="2" style="text-align: center;">SDI: In SDO: Out</td> </tr> </tbody> </table> <p>MPU Parallel interface bus and serial interface select If use RGB Interface must select serial interface. * : Fix this pin at VDDI or VSS.</p>	IM3	IM2	IM1	IM0	MCU-Interface Mode	DB Pin in use		Register/Content	GRAM	0	0	0	0	80 MCU 8-bit bus interface I	D[7:0]	D[7:0]	0	0	0	1	80 MCU 16-bit bus interface I	D[7:0]	D[15:0]	0	0	1	0	80 MCU 9-bit bus interface I	D[7:0]	D[8:0]	0	0	1	1	80 MCU 18-bit bus interface I	D[7:0]	D[17:0]	0	1	0	1	3-wire 9-bit data serial interface I	SDA: In/OUT		0	1	1	0	4-wire 8-bit data serial interface I	SDA: In/OUT		1	0	0	0	80 MCU 16-bit bus interface II	D[8:1]	D[17:10], D[8:1]	1	0	0	1	80 MCU 8-bit bus interface II	D[17:10]	D[17:10]	1	0	1	0	80 MCU 18-bit bus interface II	D[8:1]	D[17:0]	1	0	1	1	80 MCU 9-bit bus interface II	D[17:10]	D[17:9]	1	1	0	1	3-wire 9-bit data serial interface II	SDI: In SDO: Out		1	1	1	0	4-wire 8-bit data serial interface II	SDI: In SDO: Out		
IM3	IM2		IM1						IM0	MCU-Interface Mode	DB Pin in use																																																																																						
				Register/Content	GRAM																																																																																												
0	0		0	0	80 MCU 8-bit bus interface I	D[7:0]	D[7:0]																																																																																										
0	0		0	1	80 MCU 16-bit bus interface I	D[7:0]	D[15:0]																																																																																										
0	0		1	0	80 MCU 9-bit bus interface I	D[7:0]	D[8:0]																																																																																										
0	0		1	1	80 MCU 18-bit bus interface I	D[7:0]	D[17:0]																																																																																										
0	1		0	1	3-wire 9-bit data serial interface I	SDA: In/OUT																																																																																											
0	1		1	0	4-wire 8-bit data serial interface I	SDA: In/OUT																																																																																											
1	0		0	0	80 MCU 16-bit bus interface II	D[8:1]	D[17:10], D[8:1]																																																																																										
1	0		0	1	80 MCU 8-bit bus interface II	D[17:10]	D[17:10]																																																																																										
1	0		1	0	80 MCU 18-bit bus interface II	D[8:1]	D[17:0]																																																																																										
1	0	1	1	80 MCU 9-bit bus interface II	D[17:10]	D[17:9]																																																																																											
1	1	0	1	3-wire 9-bit data serial interface II	SDI: In SDO: Out																																																																																												
1	1	1	0	4-wire 8-bit data serial interface II	SDI: In SDO: Out																																																																																												
39	IM1																																																																																																
40	IM2																																																																																																

## Product Specification

	Model: XTPQ32NN01-01	Rev. No.	Issued Date.	Page.
		A	2016,04,27	9 / 19

### 6 Optical Characteristics

Item	Symbol	Condition	Min.	Typ.	Max.	Unit	Note
Transmittance (without Polarizer)	T(%)	—	—	18.0	—	—	
Contrast Ratio	CR	$\theta=0$	400	500	—	—	(1)(2)
Response time	Rising	$T_R$	—	4	8	msec	(1)(3)
	Falling	$T_F$	—	12	24		
Color gamut	S(%)			60		%	
Color chromaticity (CIE1931)	White	$W_x$		0.283	0.303	0.323	(1)(4) CF glass
		$W_y$		0.305	0.325	0.345	
	Red	$R_x$		0.606	0.626	0.646	
		$R_y$		0.314	0.334	0.354	
	Green	$G_x$		0.257	0.277	0.297	
		$G_y$		0.529	0.549	0.569	
	Blue	$B_x$		0.122	0.142	0.162	
$B_y$			0.102	0.122	0.142		
Viewing angle	Hor.	$\theta_L$	CR>10	35	45	—	Viewing Angle base on using normal Polarizer , Reference Only
		$\theta_R$		35	45	—	
	Ver.	$\theta_U$		35	45	—	
		$\theta_D$		10	20	—	
Optima View Direction	12 O'clock						(5)

## Product Specification

	Model: XTPQ32NN01-01	Rev. No.	Issued Date.	Page.
		A	2016,04,27	10 / 19

**Note (1)** Definition of Viewing Angle :

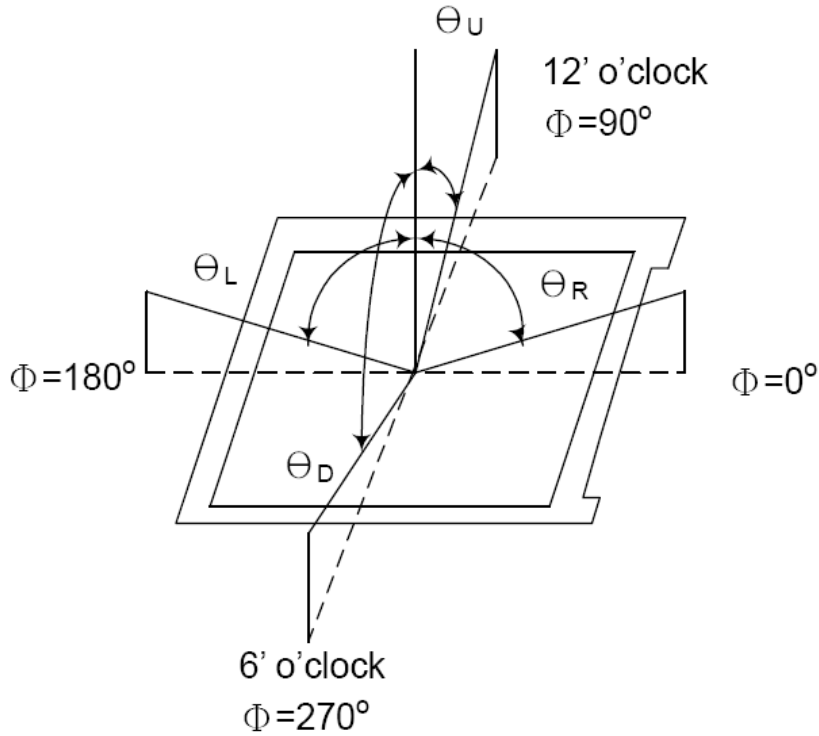

**Note (2)** Definition of Contrast Ratio(CR) :  
measured at the center point of panel

$$CR = \frac{\text{Luminance with all pixels white}}{\text{Luminance with all pixels black}}$$

**Note (3)** Definition of Response Time : Sum of  $T_R$  and  $T_F$

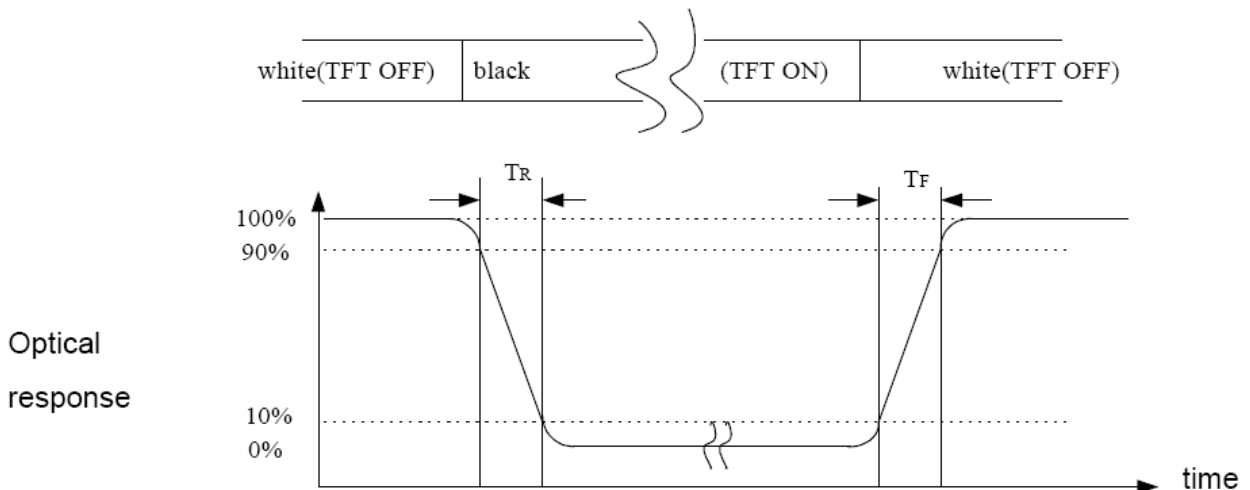

## Product Specification

	Model: XTPQ32NN01-01	Rev. No.	Issued Date.	Page.
		A	2016,04,27	11 / 19

**Note (4)** Definition of optical measurement setup

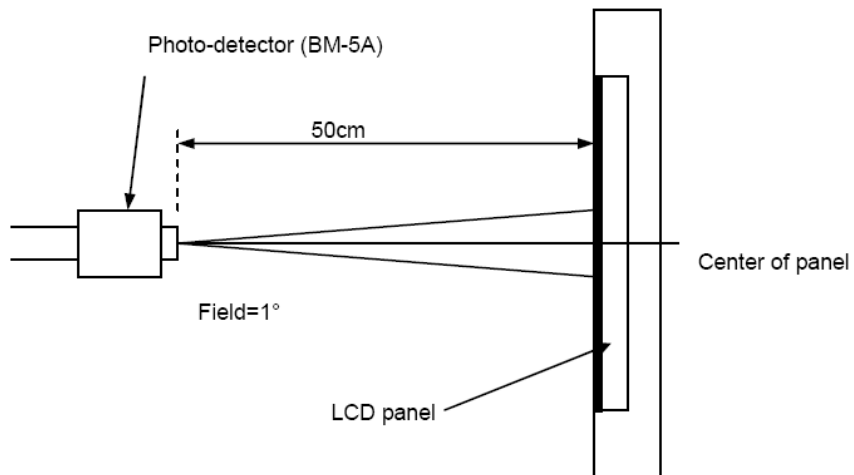



## Product Specification

	Model: XTPQ32NN01-01	Rev. No.	Issued Date.	Page.
		A	2016,04,27	13 / 19

### 8 Reliability Condition for LCD

No change on display and in operation under the following test condition.

Condition: Unless otherwise specified, tests will be conducted under the following condition.

Temperature:  $20 \pm 5^\circ \text{C}$                       Humidity:  $65 \pm 5\% \text{RH}$

Tests will be not conducted under functioning state.

No.	Parameter	Condition	Notes
1	High Temperature Operating	$70^\circ \text{C} \pm 2^\circ \text{C}$ , 240hrs (Operation state)	--
2	Low Temperature Operating	$-20^\circ \text{C} \pm 2^\circ \text{C}$ , 240hrs (Operation state)	--
3	High Temperature Storage	$80^\circ \text{C} \pm 2^\circ \text{C}$ , 240hrs	--
4	Low Temperature Storage	$-30^\circ \text{C} \pm 2^\circ \text{C}$ , 240hrs	--
5	High Temperature and High Humidity Operation Test	$60^\circ \text{C} \pm 2^\circ \text{C}$ , 90%, 240hrs	--
6	Vibration Test	Total fixed amplitude: 1.5mm Vibration Frequency: 10-55Hz One cycle 60 seconds to 3 direction of X, Y, Z each 15 minutes.	--

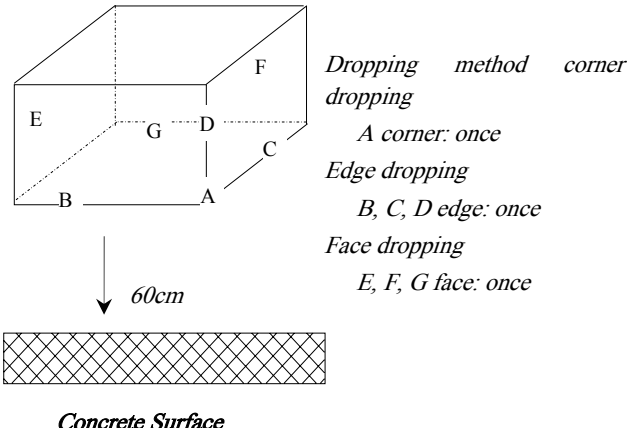
7.	Drop Test	<p>To be measured after dropping from 60cm high on the concrete surface in packing state.</p> <div style="text-align: center;">  </div>	--
----	-----------	---	----

- Notes:
1. No dew condensation to be observed.
  2. The function test shall be conducted after 4 hours storage at the normal temperature and humidity after removed from the test chamber.
  3. Vibration test will be conducted to the product itself without putting I in a container.

# Product Specification

Model: XTPQ32NN01-01

Rev. No.

Issued Date.

Page.

A

2016,04,27

14 / 19

## 9 Dimensional outlines

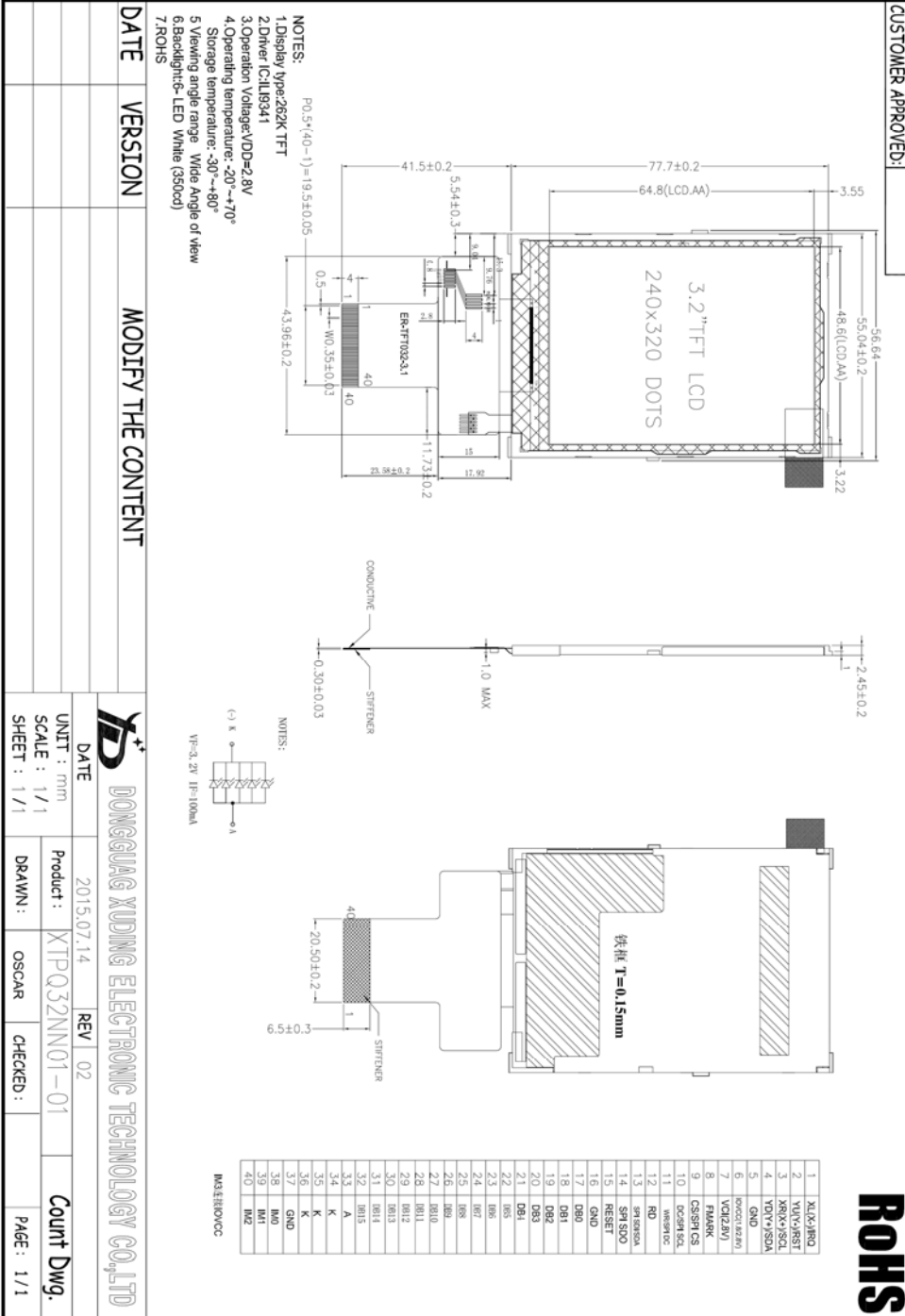

## Product Specification

	Model: XTPQ32NN01-01	Rev. No.	Issued Date.	Page.
		A	2016,04,27	15 / 19

### 10 Incoming Inspection Standards

#### 11.1 VISUAL & FUNCTION INSPECTION STANDARD

##### 11.1.1 Inspection conditions

Inspection performed under the following conditions is recommended.

Temperature :  $25\pm 5^{\circ}\text{C}$

Humidity :  $65\%\pm 10\%\text{RH}$

Viewing Angle : Normal viewing Angle.

Illumination: Single fluorescent lamp (300 to 700Lux)

Viewing distance:30-50cm

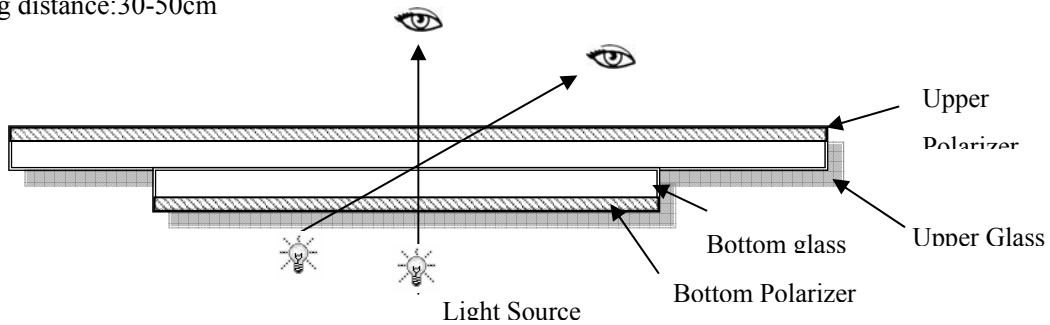

##### 11.1.2 Definition

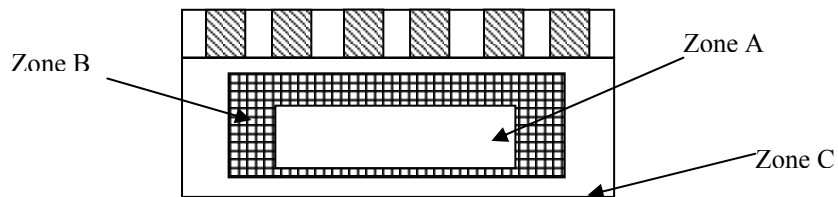

Zone A : Effective Viewing Area(Character or Digit can be seen)

Zone B : Viewing Area except Zone A

Zone C : Outside (Zone A+Zone B) which can not be seen after assembly by customer .)

Note:

As a general rule ,visual defects in Zone C can be ignored when it doesn't effect product function or appearance after assembly by customer.

##### 11.1.3 Sampling Plan

Product Specification				
	Model: XTPQ32NN01-01	Rev. No.	Issued Date.	Page.
		A	2016,04,27	16 / 19

According to GB/T 2828-2003 ; , normal inspection, Class II

AQL:

Major defect	Minor defect
0.65	1.5

LCD: Liquid Crystal Display , TP: Touch Panel , LCM: Liquid Crystal Module

No	Items to be inspected	Criteria	Classification of defects
1	Functional defects	1) No display, Open or miss line 2) Display abnormally, Short 3) Backlight no lighting, abnormal lighting. 4) TP no function	Major
2	Missing	Missing component	
3	Outline dimension	Overall outline dimension beyond the drawing is not allowed	
4	Color tone	Color unevenness, refer to limited sample	Minor
5	Soldering appearance	Good soldering , Peeling off is not allowed.	
6	LCD/Polarizer/TP	Black/White spot/line, scratch, crack, etc.	

#### 11.1.4 Criteria (Visual)

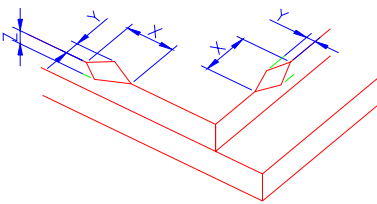
Number	Items	Criteria(mm)						
1.0 LCD Crack/Broken	(1) The edge of LCD broken	 <table border="1" data-bbox="847 1715 1391 1870"> <thead> <tr> <th>X</th> <th>Y</th> <th>Z</th> </tr> </thead> <tbody> <tr> <td>≤3.0mm</td> <td>&lt;Inner border line of the seal</td> <td>≤T</td> </tr> </tbody> </table>	X	Y	Z	≤3.0mm	<Inner border line of the seal	≤T
X	Y	Z						
≤3.0mm	<Inner border line of the seal	≤T						

NOTE:

X: Length

Y: Width

## Product Specification

	Model: XTPQ32NN01-01	Rev. No.	Issued Date.	Page.
		A	2016,04,27	17 / 19

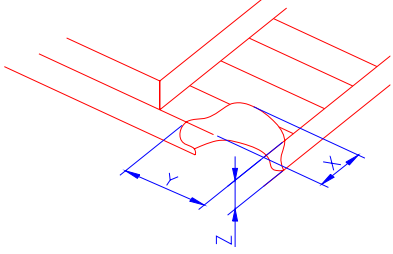
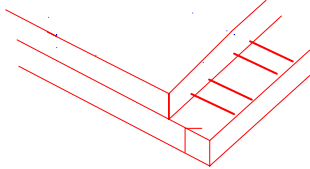
Z: Height L: Length of ITO, T: Height of LCD	(2)LCD corner broken	 <table border="1" style="margin: 10px auto; border-collapse: collapse;"> <thead> <tr> <th style="padding: 5px;">X</th> <th style="padding: 5px;">Y</th> <th style="padding: 5px;">Z</th> </tr> </thead> <tbody> <tr> <td style="padding: 5px;"><math>\leq 3.0\text{mm}</math></td> <td style="padding: 5px;"><math>\leq L</math></td> <td style="padding: 5px;"><math>\leq T</math></td> </tr> </tbody> </table>	X	Y	Z	$\leq 3.0\text{mm}$	$\leq L$	$\leq T$
	X	Y	Z					
$\leq 3.0\text{mm}$	$\leq L$	$\leq T$						
(3) LCD crack	 <p style="text-align: center;">Crack Not allowed</p>							

## Product Specification

Model: XTPQ32NN01-01	Rev. No.	Issued Date.	Page.
	A	2016,04,27	18 / 19

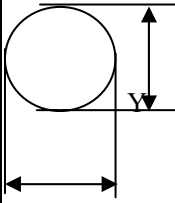
Number	Items	Criteria (mm)																																																																	
2.0	Spot defect  $\Phi = (X+Y)/2$	① light dot (LCD/TP/Polarizer black/white spot, light dot, pinhole, dent, stain) <table border="1" style="width: 100%; border-collapse: collapse;"> <thead> <tr> <th rowspan="2" style="text-align: center;">Zone Size (mm)</th> <th colspan="3" style="text-align: center;">Acceptable Qty</th> </tr> <tr> <th style="text-align: center;">A</th> <th style="text-align: center;">B</th> <th style="text-align: center;">C</th> </tr> </thead> <tbody> <tr> <td style="text-align: center;"><math>\Phi \leq 0.10</math></td> <td colspan="3" style="text-align: center;">Ignore</td> </tr> <tr> <td style="text-align: center;"><math>0.10 &lt; \Phi \leq 0.15</math></td> <td colspan="3" style="text-align: center;">3( distance <math>\geq 10\text{mm}</math>)</td> </tr> <tr> <td style="text-align: center;"><math>0.15 &lt; \Phi \leq 0.2</math></td> <td colspan="3" style="text-align: center;">1</td> </tr> <tr> <td style="text-align: center;"><math>0.2 &lt; \Phi</math></td> <td colspan="3" style="text-align: center;">0</td> </tr> </tbody> </table> ② Dim spot (LCD/TP/Polarizer dim dot, light leakage, dark spot) <table border="1" style="width: 100%; border-collapse: collapse;"> <thead> <tr> <th rowspan="2" style="text-align: center;">Zone Size (mm)</th> <th colspan="3" style="text-align: center;">Acceptable Qty</th> </tr> <tr> <th style="text-align: center;">A</th> <th style="text-align: center;">B</th> <th style="text-align: center;">C</th> </tr> </thead> <tbody> <tr> <td style="text-align: center;"><math>\Phi \leq 0.1</math></td> <td colspan="3" style="text-align: center;">Ignore</td> </tr> <tr> <td style="text-align: center;"><math>0.1 &lt; \Phi \leq 0.2</math></td> <td colspan="3" style="text-align: center;">2( distance <math>\geq 10\text{mm}</math>)</td> </tr> <tr> <td style="text-align: center;"><math>0.2 &lt; \Phi \leq 0.3</math></td> <td colspan="3" style="text-align: center;">1</td> </tr> <tr> <td style="text-align: center;"><math>\Phi &gt; 0.3</math></td> <td colspan="3" style="text-align: center;">0</td> </tr> </tbody> </table> ③ Polarizer accidented spot <table border="1" style="width: 100%; border-collapse: collapse;"> <thead> <tr> <th rowspan="2" style="text-align: center;">Zone Size (mm)</th> <th colspan="3" style="text-align: center;">Acceptable Qty</th> </tr> <tr> <th style="text-align: center;">A</th> <th style="text-align: center;">B</th> <th style="text-align: center;">C</th> </tr> </thead> <tbody> <tr> <td style="text-align: center;"><math>\Phi \leq 0.2</math></td> <td colspan="3" style="text-align: center;">Ignore</td> </tr> <tr> <td style="text-align: center;"><math>0.2 &lt; \Phi \leq 0.5</math></td> <td colspan="3" style="text-align: center;">2( distance <math>\geq 10\text{mm}</math>)</td> </tr> <tr> <td style="text-align: center;"><math>\Phi &gt; 0.5</math></td> <td colspan="3" style="text-align: center;">0</td> </tr> </tbody> </table>	Zone Size (mm)	Acceptable Qty			A	B	C	$\Phi \leq 0.10$	Ignore			$0.10 < \Phi \leq 0.15$	3( distance $\geq 10\text{mm}$ )			$0.15 < \Phi \leq 0.2$	1			$0.2 < \Phi$	0			Zone Size (mm)	Acceptable Qty			A	B	C	$\Phi \leq 0.1$	Ignore			$0.1 < \Phi \leq 0.2$	2( distance $\geq 10\text{mm}$ )			$0.2 < \Phi \leq 0.3$	1			$\Phi > 0.3$	0			Zone Size (mm)	Acceptable Qty			A	B	C	$\Phi \leq 0.2$	Ignore			$0.2 < \Phi \leq 0.5$	2( distance $\geq 10\text{mm}$ )			$\Phi > 0.5$	0		
Zone Size (mm)	Acceptable Qty																																																																		
	A	B	C																																																																
$\Phi \leq 0.10$	Ignore																																																																		
$0.10 < \Phi \leq 0.15$	3( distance $\geq 10\text{mm}$ )																																																																		
$0.15 < \Phi \leq 0.2$	1																																																																		
$0.2 < \Phi$	0																																																																		
Zone Size (mm)	Acceptable Qty																																																																		
	A	B	C																																																																
$\Phi \leq 0.1$	Ignore																																																																		
$0.1 < \Phi \leq 0.2$	2( distance $\geq 10\text{mm}$ )																																																																		
$0.2 < \Phi \leq 0.3$	1																																																																		
$\Phi > 0.3$	0																																																																		
Zone Size (mm)	Acceptable Qty																																																																		
	A	B	C																																																																
$\Phi \leq 0.2$	Ignore																																																																		
$0.2 < \Phi \leq 0.5$	2( distance $\geq 10\text{mm}$ )																																																																		
$\Phi > 0.5$	0																																																																		

## Product Specification

	Model: XTPQ32NN01-01	Rev. No.	Issued Date.	Page.
		A	2016,04,27	19 / 19

	Line defect (LCD/TP /Polarizer black/white line, scratch, stain)	<table border="1" style="width: 100%; border-collapse: collapse; text-align: center;"> <thead> <tr> <th rowspan="2">Width(mm)</th> <th rowspan="2">Length(mm)</th> <th colspan="3">Acceptable Qty</th> </tr> <tr> <th>A</th> <th>B</th> <th>C</th> </tr> </thead> <tbody> <tr> <td><math>\Phi \leq 0.03</math></td> <td>Ignore</td> <td colspan="2">Ignore</td> <td rowspan="3">Ignore</td> </tr> <tr> <td><math>0.03 &lt; W \leq 0.05</math></td> <td><math>L \leq 3.0</math></td> <td colspan="2"><math>N \leq 2</math></td> </tr> <tr> <td><math>0.05 &lt; W \leq 0.08</math></td> <td><math>L \leq 2.0</math></td> <td colspan="2"><math>N \leq 2</math></td> </tr> <tr> <td><math>0.08 &lt; W</math></td> <td colspan="4">Define as spot defect</td> </tr> </tbody> </table>	Width(mm)	Length(mm)	Acceptable Qty			A	B	C	$\Phi \leq 0.03$	Ignore	Ignore		Ignore	$0.03 < W \leq 0.05$	$L \leq 3.0$	$N \leq 2$		$0.05 < W \leq 0.08$	$L \leq 2.0$	$N \leq 2$		$0.08 < W$	Define as spot defect			
Width(mm)	Length(mm)	Acceptable Qty																										
		A	B	C																								
$\Phi \leq 0.03$	Ignore	Ignore		Ignore																								
$0.03 < W \leq 0.05$	$L \leq 3.0$	$N \leq 2$																										
$0.05 < W \leq 0.08$	$L \leq 2.0$	$N \leq 2$																										
$0.08 < W$	Define as spot defect																											
3.0	Polarizer Bubble	<table border="1" style="width: 100%; border-collapse: collapse; text-align: center;"> <thead> <tr> <th rowspan="2">Zone Size (mm)</th> <th colspan="3">Acceptable Qty</th> </tr> <tr> <th>A</th> <th>B</th> <th>C</th> </tr> </thead> <tbody> <tr> <td><math>\Phi \leq 0.2</math></td> <td colspan="2">Ignore</td> <td rowspan="4">Ignore</td> </tr> <tr> <td><math>0.2 &lt; \Phi &lt; 0.4</math></td> <td colspan="2">2(distance <math>\geq 10</math>mm)</td> </tr> <tr> <td><math>0.4 &lt; \Phi \leq 0.6</math></td> <td colspan="2">1</td> </tr> <tr> <td><math>0.6 &lt; \Phi</math></td> <td colspan="2">0</td> </tr> </tbody> </table>	Zone Size (mm)	Acceptable Qty			A	B	C	$\Phi \leq 0.2$	Ignore		Ignore	$0.2 < \Phi < 0.4$	2(distance $\geq 10$ mm)		$0.4 < \Phi \leq 0.6$	1		$0.6 < \Phi$	0							
Zone Size (mm)	Acceptable Qty																											
	A	B	C																									
$\Phi \leq 0.2$	Ignore		Ignore																									
$0.2 < \Phi < 0.4$	2(distance $\geq 10$ mm)																											
$0.4 < \Phi \leq 0.6$	1																											
$0.6 < \Phi$	0																											
4.0	SMT	According to IPC-A-610C class II standard . Function defect and missing part are major defect ,the others are minor defect.																										